



Alabama Port Authority
Specification Booklet

Project Name APA Pinto Cranes Structural Weld Inspection - **REBID**

Location Mobile, Alabama

Project # 11371

Task # 2

JUNE 27, 2024

SPECIFICATIONS AND CONTRACT DOCUMENTS



PORT OF MOBILE
ALABAMA PORT AUTHORITY

John C. Driscoll, Director & CEO

Kay Ivey, Governor of Alabama

ISSUED BY

Engineering Services Department



Alabama Port Authority
Specification Booklet

Project Name APA Pinto Cranes Structural Weld Inspection - **REBID**

Location Mobile, Alabama

Project # 11371

Task # 2

JUNE 27, 2024

1 | Page

TABLE OF CONTENTS

DIVISION I..... BID DOCUMENTS

DIVISION II CONTRACT DOCUMENTS

DIVISION III SPECIAL PROVISIONS

DIVISION IV GENERAL PROVISIONS

DIVISION V INSPECTION SPECIFICATIONS

APPENDIX A.STRUCTURAL INSPECTION MANUAL – EXAMPLE SHEETS

APPENDIX B.....WELD FORM – CONTROL COPY

APPENDIX C..... SUMMARY OF INSPECTION DOCUMENT



Alabama Port Authority
Specification Booklet

Project Name APA Pinto Cranes Structural Weld Inspection - **REBID**

Location Mobile, Alabama

Project # 11371

Task # 2

JUNE 27, 2024

2 | Page

BID DOCUMENTS

DIVISION I
INDEX

INVITATION FOR BIDSI-1

INSTRUCTIONS TO BIDDERS I-3

PROPOSALI-6

BID BONDI-9

CERTIFICATE OF COMPLIANCEI-10



Alabama Port Authority
Specification Booklet

Project Name APA Pinto Cranes Structural Weld Inspection - **REBID**

Location Mobile, Alabama

Project # 11371

Task # 2

JUNE 27, 2024

I-1 | Page

INVITATION TO BID

Sealed bid proposals will be received via courier to the Alabama Port Authority, 1400 Alabama State Docks Blvd, Room 216, Administration Building, Mobile, Alabama 36602 by **2:00 P.M., on July 11, 2024**. The right is reserved, as the interest of the Alabama Port Authority may require, to reject all bids through a Notice of Non-award or otherwise, and to waive informalities in bids received.

PROJECT 11371
APA PINTO CRANES STRUCTURAL WELD INSPECTION
MOBILE, ALABAMA

The work consists principally of performing NDE structural weld inspections of APA Pinto Island Slab Handling Cranes 1, 2, and 3 based on the requirements as indicated in the Structural Inspection Manual and Specifications. The structural weld inspection will include visual testing (VT), magnetic particle testing (MT), liquid penetrant testing (PT), ultrasonic testing (UT), and bolt testing (BT). The work will also include the reinspection of any areas that are repaired as a result of the inspection findings. The Contractor shall provide two (2) inspectors on-site throughout the inspection process and confirm continuity of inspectors throughout the inspection of all three cranes. Access equipment will be provided by APA. All cleaning, paint removal, potential repair work, and repainting will be completed by APA.

Specifications, proposal forms, bid and performance bond forms, and plans are available on the Alabama Port Authority website at www.alports.com. For additional project contractual information, please contact the APA Project Manager, Brandon Taylor at (251)441-7243 (Email to Brandon.Taylor@alport.com). For technical information, please contact the APTIM Project Manager, Tripp Meador at (251) 380-1232 (email at Tripp.Meador@aptim.com).

A virtual **Pre-Bid Meeting (via TEAMS) is scheduled for Monday July 1, 2024 at 1300**. For the TEAMS invitation, each prospective bidder must submit a list of attendees (names and email addresses) to the ASPA Project Manager at least 24 hours in advance of the pre-bid meeting. APA/APTIM will provide a TEAMS Meeting invitation/link for use to access the meeting. **Bidder attendance (via TEAMS) is MANDATORY – however – if a Bidder attended the original project TEAMS pre-bid on June 12, 2024, attendance at the July 1 meeting is considered satisfied as the meeting content shall be the same.**

During the Pre-Bid Meeting, APA/APTIM will provide an overview of the project, including general inspection expectations and procedures, demonstration of the complete Structural Inspection Manual contents and layout and use of the AutoCAD Construction Cloud Build Software features and reporting system that has been developed for this project.



Alabama Port Authority
Specification Booklet

Project Name APA Pinto Cranes Structural Weld Inspection - **REBID**

Location Mobile, Alabama

Project # 11371

Task # 2

JUNE 27, 2024

I-2 | Page

If desired, prospective bidders may arrange for a site visit to Pinto Terminal to observe the existing conditions of the work site and Crane(s). Access to the site will require a TWIC card (please refer to Item SP-15). All bidders not possessing proper access credentials must contact the APA Project Manager at least 24 hours in advance to arrange an escort and confirm an acceptable visit schedule. No same day escorts will be provided. All escorted individuals are required to have a valid state or federal identification. All vehicles entering ASPA properties are required to have proof of vehicle registration and insurance.

Each bidder shall satisfy oneself as to the character, quality, and quantities of work to be performed, and as to the requirements of the proposed contract. The submission of a proposal shall be proof that the bidding Contractor has made such examination and is satisfied as to the conditions to be encountered in performing the work and as to the requirements of the proposed Contract. All bidding Contractors must be currently certified as a certified weld inspectors per the requirements of AWS.

A Guarantee will be required with each bid as follows: At least five (5%) percent of the amount bid, but in no event more than Ten Thousand (\$10,000) Dollars, shall be furnished in the form of a certified check or bid bond payable to the Alabama Port Authority.

A Performance Bond in an amount not less than the sum bid will be required at the signing of the contract and, in addition as/if applicable, a bond in an amount not less than One Hundred (100%) percent of the contract price, insuring payment of all labor and material.

Proposals shall be valid for forty-five (45) days (ie: until August 25, 2024).

The right is reserved, as the interest of the Alabama Port Authority may require, to reject any and all bids and to waive informalities in bids received.



Alabama Port Authority
Specification Booklet

Project Name APA Pinto Cranes Structural Weld Inspection - **REBID**

Location Mobile, Alabama

Project # 11371

Task # 2

JUNE 27, 2024

I-3 | Page

INSTRUCTIONS TO BIDDERS

1.0 ADDENDA AND INTERPRETATIONS

All questions about the meaning or intent of the Contract Documents shall be submitted to the Engineer in writing on or before **July 8, 2024**. Replies will be issued by Addenda mailed or delivered to all parties recorded as having received the bidding documents. All addenda so issued shall become part of the Contract Documents. Only questions answered by formal written Addenda will be binding. Oral and other interpretations or clarifications will be without legal effect.

2.0 SUBMISSION OF PROPOSALS

Before submitting his proposal, the Contractor shall comply with the following:

- a) The Proposals shall be filled in ink on the form provided herein and all blank spaces in the form shall be fully filled. The signature shall be in long hand and the complete form shall be without interlineations, alteration or erasure.
- b) Provide Bidder's overall qualifications for the project. Include similar project history / experience / capabilities of Inspection Company and general company expertise and capabilities.
- c) Provide details on the expertise and related project resumes of the proposed project inspection team.
- d) Attach a certified check or Bid Bond in the amount of 5% of the Proposal, but not more than \$10,000 made payable to the Alabama Port Authority
- e) Certificate of Compliance (pages 12-13 of this document)
- f) Confirmation of availability schedule for the proposed inspectors – refer to Division III – SP-03 for APA's tentative project timeline.
- g) Contractor's only payment for this project are the rates proposed below. Therefore, all project costs, (for example: bonds, insurance, Port access credentials, testing equipment, inspection supplies, etc..), shall be included in the rates proposed.



Alabama Port Authority
Specification Booklet

Project Name APA Pinto Cranes Structural Weld Inspection - **REBID**

Location Mobile, Alabama

Project # 11371

Task # 2

JUNE 27, 2024

I-4 | Page

- h) Should APA Operations require an interruption of the inspection work while the inspection team is at site and scheduled to perform crane inspections, the stand-by rate provided shall apply. The stand by hourly rate shall apply to any full or partial days that the work is interrupted (up to a total of eight (8) hours for the day).
- i) The mobilization and demobilization costs shall be applicable for both the initial mobilization/demobilization to and from the site at the beginning and end of the project as well as any other interruptions in the project (operationally related) that require the inspections to be paused for an extended period.

All submissions, including hand-delivered packages, US Postal Service express mail, or private delivery service must be delivered to the following individual at the following address by **2:00 p.m. CDT on July 11, 2024**.

Email submissions will be accepted – provided that the emailed version contains the complete proposal package as required **and** that the matching hard copy version is delivered to the following individual at the following address not later than 2:00 p.m. CDT on July 19, 2024.

Alabama Port Authority

Attn: Brandon Taylor, P.E., Facilities Engineer

1400 Alabama State Docks Boulevard, Suite 216

Mobile, AL 36602

(251) 441-7243

Brandon.Taylor@alports.com

Respondents shall furnish one (1) hardcopy and one (1) electronic copy on a CD or USB drive in their submission package.

The submission package shall be placed in a sealed envelope with the Bidder's name, the project, and the time and date of bid opening shown on the outside of the envelope.

Respondents are responsible for effective delivery by the above deadline, and late submissions will be rejected without opening and returned to the sender. APA accepts no responsibility for misdirected or lost proposals. Fax submissions shall not be accepted.



Alabama Port Authority
Specification Booklet

Project Name APA Pinto Cranes Structural Weld Inspection - **REBID**

Location Mobile, Alabama

Project # 11371

Task # 2

JUNE 27, 2024

I-5 | Page

3.0 SELECTION / RANKING CRITERIA

APA will review the bid package documents/information received and score each bid proposal based on the below evaluation criteria / weighting system:

60 Points - Price

15 Points - Expertise and related project resumes of the proposed project inspection team

15 Points - Similar project history/experience/capabilities of Inspection Company

10 Points - Availability of Inspectors to Satisfy Proposed Inspection Timeline

Total Points – 100

ASPA may elect to issue clarification questions to the higher ranked Bidder(s) prior to final completion the ranking process.

Upon identification of the highest ranked Bidder, a Notification of Intent to Award will be issued by APA to initiate execution of the contract. Failure to arrive at an executed contract with such Bidder would result in rejection of the Bidder and commencement of contract discussion with the next highest ranked Bidder.

4.0 PROPOSAL TIMELINE

APA currently anticipates conducting this procurement in accordance with the following list of milestones. This schedule is subject to revision and APA reserves the right to modify this schedule as it finds necessary, at its sole discretion.

- Advertise RFP: June 26, 2024
- Mandatory Pre-Bid Meeting July 1, 2024
- Deadline to submit questions: July 8, 2024
- ASPA Response to questions (final responses) July 9, 2024
- RFP Submission: July 11, 2024
- Notification of Intent to Award Date: July 22, 2024



Alabama Port Authority
Specification Booklet

Project Name APA Pinto Cranes Structural Weld Inspection - **REBID**

Location Mobile, Alabama

Project # 11371

Task # 2

JUNE 27, 2024

I-6 | Page

PROPOSAL

Proposal of:

Address:

Date:

To: STATE OF ALABAMA, Alabama Port Authority, Mobile, Alabama

Gentlemen:

The undersigned, as Bidder, hereby declares that he has examined the site of the work and informed himself fully in regard to all conditions pertaining to the place where the work is to be done; that he has examined the plans and specifications for the work and contractual documents relative thereto, and has read all Special Provisions and Specifications furnished; and that he has satisfied himself relative to all aspects of the work to be performed and especially to those factors affecting cost, progress, or performance.

The Bidder proposes and agrees, if this bid is accepted, to contract with the Owner in the form of contract specified, to furnish all necessary materials, equipment, tools, apparatus, means of transportation, labor and incidentals to perform in a satisfactory manner, the work described in the Contract Specifications and Drawings for the Alabama Port Authority, for the prices listed below to complete:

PROJECT 11371
APA PINTO CRANES STRUCTURAL WELD INSPECTION
MOBILE, ALABAMA

In full and complete accordance with the shown, noted, described and reasonable intended requirements of the plans, specifications and contract documents to the full and entire satisfaction of the Owner with a definite understanding that no money will be allowed for extra work except as set forth in the attached contract documents.

It is agreed that the description under each item, being briefly stated, implies, although it does not mention, all incidentals and that the prices stated are intended to cover all such work materials and incidentals as constitute Bidder’s obligation as described in the specifications and any details not specifically mentioned, but evidently included in the contract shall be compensated for the item which most logically includes it.

Bidder agrees that he will commence the work within the time allotted by the Contract Documents with an adequate force, plant, and equipment and that the work will be completed within time schedules outlined in Special Provisions Article SP-3.



Alabama Port Authority
Specification Booklet

Project Name APA Pinto Cranes Structural Weld Inspection - **REBID**

Location Mobile, Alabama

Project # 11371

Task # 2

JUNE 27, 2024

I-7 | Page

The Bidder further agrees that, in case of failure on his part to execute the Contract and required bonds within ten (10) calendar days from the date written notice of award if mailed or otherwise delivered to the Bidder, the certified check or bid bond accompanying this bid and the monies payable thereon shall be paid into the funds of the Owner not as penalty, but as a liquidation of a reasonable portion of the damages incurred by the Owner due to the Bidder’s failure to execute the Contract.

Items not specifically noted in the schedule of prices shall be considered ancillary to the project and be absorbed in the bid items.

SCHEDULE OF PRICES - REBID

DESCRIPTION		ESTIMATED QTY	UNIT OF MEASURE	UNIT PRICE, \$	ESTIMATED VALUE, \$
I. INSPECTIONS - SLAB HANDLING CRANE 1, 2, AND 3					
I.1 Crane 1 Inspection					
1	Mobilization	1	Per Occurrence	\$	\$
2	Demobilization	1	Per Occurrence	\$	\$
3	Structural Weld Inspection – Labor Regular Time	720 Hours	Per Hour	\$	\$
4	Structural Weld Inspection – Labor Overtime	360 Hours	Per Hour	\$	\$
5	Structural Weld Inspection – Per Diem (local transportation, hotel, meals, misc, etc)	126 man days	Per Day	\$	\$
6	Stand-By Rate Labor Regular Time	N/A	Hourly		N/A
TOTAL PROJECT BID (ESTIMATED VALUE OF ITEMS 1, 2, 3, 4 & 5)					\$

Note: All project costs necessary for the inspectors to complete the required work shall be included the rates provided (for example, bonds, insurance, Port access credentials, testing equipment, inspection supplies, etc..).

Rates shall be supplied for all potential hours worked on the project including the first 8 hours in a day and 40 hours in a week as well as hours in excess of each. If the rate would be the same, then the same rate would apply

_____ Dollars
(In Words)



Alabama Port Authority
Specification Booklet

Project Name APA Pinto Cranes Structural Weld Inspection - **REBID**

Location Mobile, Alabama

Project # 11371

Task # 2

JUNE 27, 2024

I-8 | Page

I, the undersigned bidder, hereby acknowledge receipt of the following addenda:

ADDENDUM NO. _____

ADDENDUM NO. _____

ADDENDUM NO. _____

Contractor's Signature:

Contractor

Company _____

Name

Title

Date



Alabama Port Authority
Specification Booklet

Project Name APA Pinto Cranes Structural Weld Inspection - **REBID**

Location Mobile, Alabama

Project # 11371

Task # 2

JUNE 27, 2024

I-9 | Page

BID BOND

KNOW ALL MEN BY THESE PRESENTS, that we, undersigned, _____

_____ as Principal, and _____

as Surety, are hereby held and bound unto The Alabama Port Authority as **OWNER** in the Penal sum of _____ for the payment of which will and truly be made, we hereby jointly and severally bind ourselves, successors and assigns. Signed, the _____ day of _____, 20__.

The Condition of the above obligation is such that whereas the Principal has submitted to the Alabama Port Authority a certain BID, attached hereto and hereby made a part hereof to enter into a contract in writing, for the Pinto Crane Structural Weld Inspection, Project 11371 Task #1.

NOW, THEREFORE,

- (a) If said BID shall be rejected, or
- (b) If said BID shall be accepted and the Principal shall execute and deliver a contract in the form of Contract attached hereto (Properly completed in accordance with said BID) and shall furnish a BOND for his faithful performance of said contract, and for the payment of all persons performing labor or furnishing materials in connection therewith, and shall in all other respects perform the agreement created by the acceptance of said BID, then this obligation shall be void, otherwise the same shall remain in force and effect; it being expressly understood and agreed that the liability of the Surety for any and all claims hereunder shall, in no event, exceed the panel amount of this obligation as herein stated.

The Surety, for value received, hereby stipulates and agrees that the obligations of said Surety and its **BOND** shall in no way be impaired or affected by any extension of time within which the **OWNER** may accept such BID; and said Surety does hereby waive notice of any such extension.

IN WITNESS WHEREOF, the Principal and the Surety have hereunto set their hands and seals, and such of them as are corporations have caused their corporate seals to be hereto affixed and these presents to be signed by their proper officers, the day and year first set forth above.

Principal	
Surety	
By	

State of _____

County of _____



Alabama Port Authority
Specification Booklet

Project Name APA Pinto Cranes Structural Weld Inspection - **REBID**

Location Mobile, Alabama

Project # 11371

Task # 2

JUNE 27, 2024

I-10 | Page

CERTIFICATE OF COMPLIANCE WITH THE BEASON-HAMMON ALABAMA TAXPAYER AND CITIZEN PROTECTION ACT (ACT 2011-535, as amended by Act 2012-491)

DATE: _____

RE Contract/Grant/Incentive (describe by number or subject):

_____ by and between

_____ (Contractor/Grantee) and

_____ (State Agency, Department or Public Entity)

The undersigned hereby certifies to the State of Alabama as follows:

1. The undersigned holds the position of _____ with the Contractor/Grantee named above, and is authorized to provide representations set out in this Certificate as the official and binding act of that entity, and has knowledge of the provisions of THE BEASON-HAMMON ALABAMA TAXPAYER AND CITIZEN PROTECTION ACT (ACT 2011-535 of the Alabama Legislature, as amended by Act 2012-491) which is described herein as "the Act".
2. Using the following definitions from Section 3 of the Act, select and initial either (a) or (b), below, to describe the Contractor/Grantee's business structure.

BUSINESS ENTITY. Any person or group of persons employing one or more persons performing or engaging in any activity, enterprise, profession, or occupation for gain, benefit, advantage, or livelihood, whether for profit or not for profit. "Business entity" shall include, but not be limited to the following:

- a. Self-employed individuals, business entities filing articles of incorporation, partnerships, limited partnerships, limited liability companies, foreign corporations, foreign limited partnerships, foreign limited liability companies authorized to transact business in this state, business trusts, and any business entity that registers with the Secretary of State.
- b. Any business entity that possesses a business license, permit, certificate, approval, registration, charter, or similar form of authorization issued by the state, any business entity that is exempt by law from obtaining such a business license and any business entity that is operating unlawfully without a business license.



Alabama Port Authority
Specification Booklet

Project Name APA Pinto Cranes Structural Weld Inspection - **REBID**

Location Mobile, Alabama

Project # 11371

Task # 2

JUNE 27, 2024

I-11 | Page

EMPLOYER. Any person, firm, corporation, partnership, joint stock association, agent, manager, representative, foreman, or other person having control or custody of any employment, place of employment, or of any employee, including any person or entity employing any person for hire within the State of Alabama, including a public employer. This term shall not include the occupant of a household contracting with another person to perform casual domestic labor within the household.

- a. The Contractor/Grantee is a business entity or employer as those terms are defined in Section 3 of the Act.
 - b. The Contractor/Grantee is not a business entity or employer as those terms are defined in Section 3 of the Act.
3. As of the date of this Certificate, Contractor/Grantee does not knowingly employ an unauthorized alien within the State of Alabama and hereafter it will not knowingly employ, hire for employment, or continue to employ an unauthorized alien within the State of Alabama.
 4. Contractor/Grantee is enrolled in E-Verify unless it is not eligible to enroll because of the rules of that program or other factors beyond its control.

Certified this ____ day of _____, 20____

Name of Contractor/Grantee/Recipient

By: _____

Its _____

The above Certification was signed in my presence by the person whose name appears above,

on this ____ day of _____, 20____

WITNESS:

Signature

Printed Name of Witness



Alabama Port Authority
Specification Booklet

Project Name APA Pinto Cranes Structural Weld Inspection - **REBID**

Location Mobile, Alabama

Project # 11371

Task # 2

JUNE 27, 2024

II-1 | Page

CONTRACT DOCUMENTS

DIVISION II
INDEX

PERFORMANCE BOND II-1

LABOR AND MATERIAL BOND II-3

ACKNOWLEDGMENT FOR CHANGE ORDERS II-5

CONTRACT II-6



Alabama Port Authority
Specification Booklet

Project Name APA Pinto Cranes Structural Weld Inspection - **REBID**

Location Mobile, Alabama

Project # 11371

Task # 2

JUNE 27, 2024

II-1 | Page

PERFORMANCE BOND

KNOW ALL MEN BY THESE PRESENTS:

That: _____
(Name of Contractor)

(Address of Contractor)

(City, State, Zip)

I, a(n) _____ corporation, hereinafter called Principal, and
(state of domicile)

(Name of Surety)

(Address of Surety)

hereinafter called Surety, are held and firmly bound unto the Alabama Port Authority hereinafter called OWNER, in the penal sum of _____ DOLLARS, (\$ _____) (100% of the Contract Amount) in lawful money of the United States, for the payment of which sum well and truly to be made, we bind ourselves, successors, and assigns, jointly and severally, firmly by these presents.

THE CONDITION OF THIS OBLIGATION is such that whereas, the Principal entered into a certain contract with the OWNER, dated the _____ day of _____, 20 ____, a copy of which is hereto attached and made a part hereof for the construction of:

APA PINTO CRANES STRUCTURAL WELD INSPECTION
MOBILE, ALABAMA

NOW, THEREFORE, if the Principal shall promptly make payments to all persons, firms, SUBCONTRACTORS, and corporations furnishing materials or performing labor in the prosecution of the WORK provided for in such contract, and any authorized extension or modification thereof, including all amounts due for materials, lubricants, fuel, repairs on machinery, equipment and tools, consumer or used in connection with the construction of such WORK, and all insurance premiums on said WORK, and for all labor performed in such WORK whether by SUBCONTRACTOR or otherwise, then this obligation shall be void; otherwise to remain in full force and effect.



Alabama Port Authority
Specification Booklet

Project Name APA Pinto Cranes Structural Weld Inspection - **REBID**

Location Mobile, Alabama

Project # 11371

Task # 2

JUNE 27, 2024

II-2 | Page

PROVIDED FURTHER, that the said Surety, for value received hereby stipulates and agrees that no change, extension of time, alteration, or addition to the terms of the contract of the WORK to be performed thereunder or the SPECIFICATIONS accompanying the same shall in any way affect its obligation on this BOND, and it does hereby waive notice of any such change, extension of time, alteration, or addition to the terms of the contract or to the WORK or to the SPECIFICATIONS.

PROVIDED, FURTHER, that no final settlement between the OWNER and the CONTRACTOR shall abridge the right of any beneficiary hereunder, whose claim may be unsatisfied.

IN WITNESS WHEREOF, this instrument is executed this _____ day of _____, 20____.

ATTEST:

(Principal) Secretary

(SEAL)

Witness as to Surety Principal

(Address)

ATTEST:

Witness as to Surety

(Address)

Principal

BY: _____ (s)

(Address)

Surety

BY: _____
Attorney-In-Fact

(Address)

NOTE: Date of BOND must not be prior to date of CONTRACT.
If CONTRACTOR is Partnership, all partners should execute BOND.



Alabama Port Authority
Specification Booklet

Project Name APA Pinto Cranes Structural Weld Inspection - **REBID**

Location Mobile, Alabama

Project # 11371

Task # 2

JUNE 27, 2024

II-3 | Page

LABOR AND MATERIAL BOND

KNOW ALL MEN BY THESE PRESENTS:

That: _____
(Name of Contractor)

(Address of Contractor)

(City, State, Zip)

I, a(n) _____ corporation, hereinafter called Principal, and
(state of domicile)

(Name of Surety)

(Address of Surety)

(City, State, Zip)

hereinafter called Surety, are held and firmly bound unto the Alabama Port Authority hereinafter called OWNER, in the penal sum of _____ DOLLARS, (\$ _____) (100% of the Contract Amount) in lawful money of the United States, for the payment of which sum well and truly to be made, we bind ourselves, successors, and assigns, jointly and severally, firmly by these presents.

THE CONDITION OF THIS OBLIGATION is such that, the Principal entered into a certain contract with the OWNER, dated the _____ day of _____, 20 __, a copy of which is hereto attached and made a part hereof for the construction of:

APA PINTO CRANES STRUCTURAL WELD INSPECTION MOBILE, ALABAMA

NOW, THEREFORE, if the Principal shall promptly make payments to all persons, firms, SUBCONTRACTORS, and corporations furnishing materials or performing labor in the prosecution of the WORK provided for in such contract, and any authorized extension or modification thereof, including all amounts due for materials, lubricants, fuel, repairs on machinery, equipment and tools, consumer or used in connection with the construction of such WORK, and all insurance premiums on said WORK, and for all labor performed in such WORK whether by SUBCONTRACTOR or otherwise, then this obligation shall be void; otherwise to remain in full force and effect.



Alabama Port Authority
Specification Booklet

Project Name APA Pinto Cranes Structural Weld Inspection - **REBID**

Location Mobile, Alabama

Project # 11371

Task # 2

JUNE 27, 2024

II-4 | Page

PROVIDED FURTHER, that the said Surety, for value received hereby stipulates and agrees that no change, extension of time, alteration, or addition to the terms of the contract of the WORK to be performed thereunder or the SPECIFICATIONS accompanying the same shall in any way affect its obligation on this BOND, and it does hereby waive notice of any such change, extension of time, alteration, or addition to the terms of the contract or to the WORK or to the SPECIFICATIONS.

PROVIDED, FURTHER, that no final settlement between the OWNER and the CONTRACTOR shall abridge the right of any beneficiary hereunder, whose claim may be unsatisfied.

IN WITNESS WHEREOF, this instrument is executed this _____ day of _____, 20____.

ATTEST:

(Principal) Secretary

(SEAL)

Witness as to Surety Principal

(Address)

ATTEST:

Witness as to Surety

(Address)

Principal

BY: _____(s)

(Address)

Surety

BY: _____

Attorney-In-Fact

(Address)

NOTE: Date of BOND must not be prior to date of CONTRACT.
If CONTRACTOR is Partnership, all partners should execute BOND.



Alabama Port Authority
Specification Booklet

Project Name APA Pinto Cranes Structural Weld Inspection - **REBID**

Location Mobile, Alabama

Project # 11371

Task # 2

JUNE 27, 2024

II-5 | Page

ACKNOWLEDGEMENT FOR CHANGE ORDERS

TO: ALABAMA PORT AUTHORITY

**RE: APA PINTO CRANES STRUCTURAL WELD INSPECTION
MOBILE, ALABAMA**

Gentlemen:

In order to avoid the necessity of extensive amendment to the referenced Contract, the undersigned hereby acknowledges that the following conditions are those for which change orders are allowed under the Bid law:

1. Unusual and difficult circumstances which arise during the course of the execution of the Contract which could not have been reasonably foreseen.
2. Where competitive bidding for the new work will be to the serious detriment of the Owner.
3. Emergencies arising during the course of work.
4. Changes or alterations provided for in the original bid and original Contract.
5. The Contractor also acknowledges that he has read paragraph 50-04 (EXTRA WORK) and 60-17 of the (CLAIMS FOR ADJUSTMENT AND DISPUTES) of the General Provisions and agrees that "If for any reason the Contractor deems that additional compensation is due him for work or materials not clearly provided in the Contract, plans, or specifications or previously authorized as extra work, he shall notify the Engineer in writing of his intention to claim such additional compensation before he begins the work on which he bases his claim."

CONTRACTOR

BY: _____

DATE

TITLE



Alabama Port Authority
Specification Booklet

Project Name APA Pinto Cranes Structural Weld Inspection - **REBID**

Location Mobile, Alabama

Project # 11371

Task # 2

JUNE 27, 2024

II-6 | Page

CONTRACT

THIS AGREEMENT, made and executed on this _____ day of the month of _____, Two Thousand and _____ (20____), by and between The Alabama Port Authority, and _____ Contractor, domiciled in the state of _____, Party of the Second Part, and hereinafter designated as "CONTRACTOR," WITNESSETH, that in consideration of the covenants and agreements herein contained, to be performed by the parties hereto and of the payments hereinafter agreed to be made, it is mutually agreed as follows:

The CONTRACTOR shall and will provide and furnish all equipment and labor, and perform the work required to build, construct, and complete in a thorough and workmanlike manner, to the satisfaction of the Alabama Port Authority:

Project Name APA PINTO CRANES STRUCTURAL WELD INSPECTION

Project # 11371 **Task #** 2

Hereinafter called the project, for the estimated base Contract price of _____ DOLLARS, (\$ _____) and all extra work in connection therewith, and in accordance with plans, specifications, and Proposal, which are made a part thereof as fully as is set out herein, and hereby becomes a part of this Contract.

It is agreed and understood that the Alabama Port Authority shall pay, and the Contractor shall receive, the full compensation for the work performed in accordance with the Specifications.

The project shall commence and will be completed in accordance with Paragraph SP-03 of the Special Provisions.

This contract shall become effective immediately upon, and as of the date all necessary parties hereto have approached and signed the same.

By signing this contract, the contracting parties affirm, for the duration of the agreement, that they will not violate federal immigration law or knowingly employ, hire for employment, or continue to employ an unauthorized alien within the State of Alabama. Furthermore, a contracting party found to be in violation of this provision shall be deemed in breach of the agreement and shall be responsible for all damages resulting therefrom.

IN WITNESS WHEREOF, the parties of these presents have executed this Agreement in the year and day first above written.

WITNESS: _____ Alabama Port Authority

WITNESS: _____ BY: _____ Contractor Party of the Second Part

_____ BY: _____



Alabama State Port Authority
Specification Booklet

Project Name Pinto Cranes Structural Weld Inspection - **REBID**

Location Mobile, Alabama

Project # 11371

Task # 2

JUNE 27, 2024

SPECIAL PROVISIONS

DIVISION III
INDEX

SP-01 – DESCRIPTION OF WORK.....III-1

SP-02 – OWNER PURCHASE OF MATERIALS.....III-1

SP-03 – COMMENCEMENT AND COMPLETIONIII-1

SP-04 – QUALIFICATION OF BIDDERSIII-2

SP-05 – ACCEPTANCE OR REJECTION OF BIDSIII-2

SP-06 – NON-RESIDENT (OUT-OF-STATE) CONTRACTORSIII-2

SP-07– INDEMNIFICATIONIII-2

SP-08 – SUPERVISION AND OFFICE TRAILERIII-3

SP-09 – CONTRACTOR’S REPRESENTATIVEIII-3

SP-10 – METHOD OF PAYMENT.....III-3

SP-11 – INSURANCEIII-3

SP-12 – TAXPAYER AND CITIZEN PROTECTION ACT.....III-4

SP-13 – INTENT OF PLANS & SPECIFICATIONS.....III-4

SP-14 – TEMPORARY WATER & ELECTRICAL POWERIII-4

SP-15 – PORT ACCESS CREDENTIALS.....III-4



Alabama State Port Authority Specification Booklet

Project Name Pinto Cranes Structural Weld Inspection - **REBID**

Location Mobile, Alabama

Project # 11371

Task # 2

JUNE 27, 2024

III-1 | Page

SP-01 DESCRIPTION OF WORK

The work consists principally of performing NDE structural weld inspections of ASPA Pinto Island Slab Handling Cranes 1, 2, and 3 based on the requirements as indicated in the Structural Inspection Manual and Specifications. The structural weld inspection will include visual testing (VT), magnetic particle testing (MT), liquid penetrant testing (PT), ultrasonic testing (UT), and bolt testing (BT). The work will also include the reinspection of any areas that are repaired as a result of the inspection findings. The Contractor shall provide two (2) inspectors on-site throughout the inspection process and confirm continuity of inspectors throughout the inspection of all three cranes. Access equipment will be provided by ASPA. All cleaning, paint removal, potential repair work, and repainting will be completed by ASPA.

SP-02 OWNER PURCHASE OF MATERIALS – Not Applicable to this Project

The Alabama State Port Authority will authorize the Contractor to utilize its sales tax exemption status on this project. It will be the responsibility of the Contractor to complete the required paperwork once initiated by ASPA. The following items within Division IV are hereby deleted in their entirety:

- Division IV Section 20-14.2, Purchase of Materials or Equipment
- Division IV Section 20-14.3, Payment of Materials or Equipment
- Division IV Section 20-14.4, Accounting Procedures
- Division IV Section 20-14.5, Procedures
- Division IV Section 20-14.7, Project Close-Out

SP-03 COMMENCEMENT AND COMPLETION

The Contractor will be required to commence work under this contract in accordance with DIVISION IV GENERAL PROVISIONS Article 90-02 (NOTICE TO PROCEED), to prosecute said work with faithfulness and energy, and to complete the project milestones within the following time frames referenced to receipt of Notice to Proceed:

Completion of the inspection of all three cranes and release for use - estimated to be within three (3) calendar weeks per crane Monday – Saturday 8AM to 6PM

Tentative Timeline

First Crane: July 29 – August 17, 2024

Second Crane: August 19 – September 7, 2024

Third Crane: September 9 – September 28, 2024



Alabama State Port Authority Specification Booklet

Project Name Pinto Cranes Structural Weld Inspection - **REBID**

Location Mobile, Alabama

Project # 11371

Task # 2

JUNE 27, 2024

III-2 | Page

The time stated for final completion shall include final clean-up of the premises. Failure to complete work on schedule shall initiate liquidated damages, which will be assessed in accordance with the provisions of Paragraph 20-13 (LIQUIDATED DAMAGES) of DIVISION IV, GENERAL PROVISIONS.

SP-04 QUALIFICATION OF BIDDERS

In addition to the requirements of Article 20-01 and 20-03 of Division IV, GENERAL PROVISIONS, the Owner may make such investigations as he deems necessary to determine the ability of the bidder to perform the work, and the bidder shall furnish to the Owner all such information and data for this purpose as the Owner may request. The Owner reserves the right to reject any bid if the evidence submitted by, or investigation of, such bidder fails to satisfy the Owner that such bidder is properly qualified to carry out the obligations of the Contract and to complete the work contemplated therein. Conditional bids will not be accepted.

SP-05 ACCEPTANCE OR REJECTION OF BIDS

The Authority reserves the right to accept or reject any or all bids and to waive informalities.

SP-06 NON-RESIDENT (OUT-OF-STATE) CONTRACTORS – Not Applicable to this Project

Preference shall be given to resident contractors, and non-resident bidders domiciled in a state having laws granting preference to local contractors shall be awarded Alabama public contracts the same as Alabama contractors bidding under similar circumstances; and resident contractors in Alabama are to be granted preference over non-residents in awarding of contracts in the same manner and to the same extent as provided by the laws of the state of domicile of the non-resident.

Non-resident bidders must accompany any written bid documents with a written opinion of any attorney at law licensed to practice law in such non-resident bidders' state of domicile, as to the preferences, if any or none, granted by the law of that state to its own business entities whose principal places of business are in that State in the letting of any or all public contracts.

SP-07 INDEMNIFICATION

To the fullest extent permitted by law, the Contractor shall indemnify and hold harmless the Owner, the Engineer, and their agents and employees from and against all claims, damages, losses, and expenses, including, but not limited to, attorney's fees arising out of or resulting from the performance of the Work, provided that any such claim, damage, loss, or expense (1) is attributed to bodily injury, sickness, disease or death, or to injury to or destruction of tangible property (other than the Work itself) including the loss of use resulting therefrom, and (2) is caused in whole or in part by any negligent act or omission of the Contractor, any subcontractor, anyone directly or indirectly employed by any of them or anyone for whose acts any of them may be liable, regardless of whether or not it is caused in part by a party indemnified hereunder. Such obligation shall not be construed to negate, abridge, or otherwise reduce any other right or obligation of indemnity that would otherwise exist as to any party or person described in this Paragraph SP-07.



Alabama State Port Authority Specification Booklet

Project Name Pinto Cranes Structural Weld Inspection - **REBID**

Location Mobile, Alabama

Project # 11371

Task # 2

JUNE 27, 2024

III-3 | Page

In any and all claims against the Owner, the Engineer or any of their agents or employees by any employee of the Contractor, any subcontractor, anyone directly or indirectly employed by any of them or anyone for whose acts any of them may be liable, the indemnification under this Paragraph SP-07, shall not be limited in any way by any limitation on the amount or type of damages, compensation or benefits payable by or for the Contractor or any subcontractor under workers' or workmen's compensation acts, or other employee benefits acts.

SP-08 SUPERVISION & OFFICE TRAILER

The Contractor shall deem one of the two on-site inspectors as the superintendent on the Project and they shall have experience in the type of work being performed under this Contract. The Contractor shall also submit an organizational chart, which shall clearly show the Contractor's personnel assigned to the Project and the position that they hold. The chart shall also define the persons of contact with the Owner and the Engineer.

The Owner reserves the right to request changes in superintendent for incompetent actions or other reasons of due cause. Once the Contractor is notified in writing of a request to replace the superintendent, he shall do so within five (5) calendar days of such request.

The Contractor's assigned supervisor shall have responsibility for the day-to-day operations of the work and shall be the on-site safety officer responsible for implementation of the Contractor's safety program unless another named person is so assigned.

The assigned superintendent shall remain on the Project site while work under the Contract is being performed. In the superintendent's absence from the site, another named person shall be responsible for all aspects of the work. Notification of the name of the individual shall be filed with the Owner and Engineer. The Contractor shall not reassign a superintendent without the acknowledgement and approval of the Owner.

If desired, the Contractor is allowed to supply and maintain an on-site trailer for the duration of the project.

SP-09 CONTRACTOR'S REPRESENTATIVE

A representative of the Contractor shall be on the site at all times work is being conducted as required by paragraph 90-01 (SUBLETTING OF CONTRACT) of DIVISION IV. A telephone number should be given to the Engineer where he might contact the Representative after working hours in case of an emergency.

SP-10 METHOD OF PAYMENT

Contractor shall monthly invoices to ASPA, including all necessary back-up documentation for labor hours and travel expenses (if any).

ASPA will process and issue payment for legitimate costs within 30 days of receipt of the Contractor's valid invoice.



Alabama State Port Authority Specification Booklet

Project Name Pinto Cranes Structural Weld Inspection - **REBID**

Location Mobile, Alabama

Project # 11371

Task # 2

JUNE 27, 2024

III-4 | Page

SP-11 INSURANCE

The following shall apply to Section 40 (Indemnification and Insurance Requirements) of Division IV General Provisions:

- 1) Omit Section 40-04 Owner's and Contractor's Protective Liability – **Not Required**
- 2) Omit Section 40-07 Ocean Marine Coverage – **Not Required**
- 3) Omit Section 40-08 Railroad Protective Liability – **Not Required**
- 4) Omit Section 40-09 Builder's Risk or Installation Floater – **Not Required**

SP-12 TAXPAYER AND CITIZEN PROTECTION ACT

Effective October 1, 2011, the Beason-Hammon Alabama Taxpayer and Citizen Protection Act ("the Act") requires that any business entity contracting with or providing any grant or incentives to the state, including the Alabama State Port Authority, certify compliance with the Act. All Bidders must certify such compliance by executing the enclosed Certificate of Compliance and returning it to the Alabama State Port Authority along with proof of the bidding company's enrollment in the E-verify program with your bid package. The following E-Verify website link is provided for convenience: http://www.dhs.gov/files/programs/qc_1185221678150.shtm.

SP-13 INTENT OF PLANS AND SPECIFICATIONS

The following is in addition to Article 60-03 of DIVISION IV, GENERAL PROVISIONS.

Any detail which may be incomplete or lacking in the plans and specifications shall not constitute claim for extra compensation. Such detail shall be supplied by the Contractor and submitted to the Engineer in advance of its requirement on the job. The true intent of the plans and specifications is to produce a complete working facility and incomplete detail will not abrogate this intent.

SP-14 TEMPORARY WATER AND ELECTRICAL POWER

All electrical current required by the Contractor to perform testing will be provided by the OWNER. All temporary connections for electricity shall be subject to the approval of the ENGINEER.

SP-15 PORT ACCESS CREDENTIALS

All individuals doing any work on this project, including operators, supervisors, maintenance personnel, truck drivers, etc. must have a valid Transportation Worker Identification Credential (TWIC) card, ASPA badge and an ASPA vehicle decal with no exceptions. Information regarding ASPA's access policy is provided on the ASPA website at the link below.

<https://www.alports.com/port-access/>



Alabama State Port Authority
Specification Booklet

Project Name Pinto Cranes Structural Weld Inspection - **REBID**

Location Mobile, Alabama

Project # 11371

Task # 2

JUNE 27, 2024

**GENERAL PROVISIONS, CLAUSES, REQUIREMENTS
AND COVENANTS**

**DIVISION IV
INDEX**

SUBSECTION	PAGE
SECTION 10 DEFINITIONS OF TERMS.....	IV-1
SECTION 20 PROPOSAL REQUIREMENTS AND CONDITIONS.....	IV-5
20-01 PREQUALIFICATION OF BIDDERS.....	IV-5
20-02 CONTENTS OF PROPOSAL FORMS.....	IV-5
20-03 ISSUANCE OF PROPOSAL FORMS	IV-5
20-04 INTERPRETATION OF ESTIMATED PROPOSAL QUANTITIES.....	IV-5
20-05 EXAMINATION OF PLANS, SPECIFICATIONS, AND SITE.....	IV-5
20-06 PREPARATION OF PROPOSAL.....	IV-6
20-07 IRREGULAR PROPOSALS	IV-6
20-08 PROPOSAL GUARANTY.....	IV-7
20-09 DELIVERY OF PROPOSAL.....	IV-7
20-10 WITHDRAWAL OR REVISION OF PROPOSALS	IV-7
20-11 PUBLIC OPENING OF PROPOSALS.....	IV-7
20-12 DISQUALIFICATION OF BIDDERS	IV-7
20-13 LIQUIDATED DAMAGES.....	IV-7
20-14 OWNER PURCHASE OF MATERIALS	IV-8
SECTION 30 AWARD AND EXECUTION OF CONTRACT.....	IV-13
30-01 CONSIDERATION OF PROPOSALS	IV-13
30-02 AWARD OF CONTRACT	IV-13
30-03 CANCELLATION OF AWARD.....	IV-13



Alabama State Port Authority
Specification Booklet

Project Name Pinto Cranes Structural Weld Inspection - **REBID**

Location Mobile, Alabama

Project # 11371

Task # 2

JUNE 27, 2024

30-04 RETURN OF PROPOSAL GUARANTY IV-13

30-05 REQUIREMENTS OF CONTRACT BONDS..... IV-14

30-06 EXECUTION OF CONTRACT IV-14

30-07 APPROVAL OF CONTRACT..... IV-14

30-08 FAILURE TO EXECUTE CONTRACT IV-14

SECTION 40 INDEMNIFICATION AND INSURANCE REQUIREMENTS..... IV-16

40-01 INDEMNIFICATION..... IV-16

40-02 CONTRACTOR COVERAGE IV-16

40-03 COMMERCIAL GENERAL LIABILITY..... IV-16

40-04 OWNER’S AND CONTRACTOR’S PROTECTIVE LIABILITY IV-16

40-05 BUSINESS AUTOMOBILE LIABILITY IV-16

40-06 WORKERS COMPENSATION..... IV-16

40-07 OCEAN MARINE COVERAGE..... IV-17

40-08 RAILROAD PROTECTIVE LIABILITY..... IV-17

40-09 BUILDER’S RISK or INSTALLATION FLOATER IV-17

40-10 PROFESSIONAL LIABILITY COVERAGE IV-17

40-11 PROOF OF CARRIAGE OF INSURANCE IV-18

SECTION 50 SCOPE OF WORK IV-18

50-01 INTENT OF CONTRACT..... IV-18

50-02 ALTERATION OF WORK AND QUANTITIES IV-18

50-03 OMITTED ITEMS..... IV-19

50-04 EXTRA WORK IV-19

50-05 MAINTENANCE OF COMMERCE..... IV-19

50-06 REMOVAL OF EXISTING STRUCTURES IV-20

50-07 RIGHTS IN AND USE OF MATERIALS FOUND IN THE WORK..... IV-20

50-08 FINAL CLEANING UP IV-21

SECTION 60 CONTROL OF WORK..... IV-22

60-01 AUTHORITY OF THE ENGINEER IV-22



Alabama State Port Authority
Specification Booklet

Project Name Pinto Cranes Structural Weld Inspection - **REBID**

Location Mobile, Alabama

Project # 11371

Task # 2

JUNE 27, 2024

60-02 CONFORMITY WITH PLANS AND SPECIFICATIONS..... IV-22

60-03 COORDINATION OF CONTRACT, PLANS AND SPECIFICATIONS IV-23

60-04 COOPERATION OF THE CONTRACTOR..... IV-23

60-05 COOPERATION BETWEEN CONTRACTORS IV-23

60-06 CONSTRUCTION LAYOUT AND STAKES IV-24

60-07 AUTOMATICALLY CONTROLLED EQUIPMENT IV-24

60-08 AUTHORITY AND DUTIES OF INSPECTORS IV-24

60-09 INSPECTION OF THE WORK IV-24

60-10 REMOVAL OF UNACCEPTABLE AND UNAUTHORIZED WORK..... IV-25

60-11 LOAD RESTRICTIONS IV-25

60-12 MAINTENANCE DURING CONSTRUCTION IV-26

60-13 FAILURE TO MAINTAIN THE WORK..... IV-26

60-14 PARTIAL ACCEPTANCE IV-26

60-15 FINAL CONSTRUCTION INSPECTION IV-26

60-16 FINAL ACCEPTANCE IV-26

60-17 CLAIMS FOR ADJUSTMENT AND DISPUTES IV-27

SECTION 70 CONTROL OF MATERIALS..... IV-28

70-01 SOURCE OF SUPPLY AND QUALITY REQUIREMENTS..... IV-28

70-02 SAMPLES, TESTS, AND CITED SPECIFICATIONS IV-28

70-03 CERTIFICATION OF COMPLIANCE IV-28

70-04 PLANT INSPECTION..... IV-29

70-05 ENGINEER'S FIELD OFFICE AND LABORATORY IV-29

70-06 STORAGE OF MATERIALS IV-29

70-07 UNACCEPTABLE MATERIALS IV-30

70-08 OWNER-FURNISHED MATERIAL IV-30

70-09 RECEIVING MATERIALS AND EQUIPMENT IV-30

SECTION 80 LEGAL RELATIONS AND RESPONSIBILITY TO PUBLIC IV-31

80-01 LAWS TO BE OBSERVED..... IV-31



Alabama State Port Authority
Specification Booklet

Project Name Pinto Cranes Structural Weld Inspection - **REBID**

Location Mobile, Alabama

Project # 11371

Task # 2

JUNE 27, 2024

80-02 PERMITS, LICENSES, AND TAXES..... IV-31

80-03 PATENTED DEVICES, MATERIALS AND PROCESSES IV-31

80-04 RESTORATION OF SURFACES DISTURBED BY OTHERS..... IV-31

80-05 SANITARY, HEALTH, AND SAFETY PROVISIONS IV-32

80-06 PUBLIC CONVENIENCE AND SAFETY IV-32

80-07 BARRICADES, WARNING SIGNS, AND HAZARD MARKINGS..... IV-32

80-08 USE OF EXPLOSIVES IV-33

80-09 PROTECTION AND RESTORATION OF PROPERTY AND LANDSCAPE IV-33

80-10 RESPONSIBILITY FOR DAMAGE CLAIMS IV-33

80-11 THIRD PARTY BENEFICIARY CLAUSE..... IV-34

80-12 OPENING SECTIONS OF THE WORK FOR OCCUPANCY IV-34

80-13 CONTRACTOR’S RESPONSIBILITY FOR WORK..... IV-34

80-14 CONTRACTOR'S RESPONSIBILITY FOR UTILITY SERVICE AND FACILITIES OF
 OTHERS IV-35

80-15 FURNISHING RIGHTS-OF-WAY IV-36

80-16 PERSONAL LIABILITY OF PUBLIC OFFICIALS IV-36

80-17 NO WAIVER OF LEGAL RIGHTS IV-36

80-18 ENVIRONMENTAL PROTECTION IV-36

80-19 ARCHAEOLOGICAL AND HISTORICAL FINDINGS IV-36

SECTION 90 PROSECUTION AND PROGRESS IV-38

90-01 SUBLETTING OF CONTRACT IV-38

90-02 NOTICE TO PROCEED IV-38

90-03 PROSECUTION AND PROGRESS..... IV-38

90-04 LIMITATION OF OPERATIONS..... IV-38

90-05 CHARACTER OF WORKERS, METHODS AND EQUIPMENT IV-38

90-06 TEMPORARY SUSPENSION OF THE WORK IV-39

90-07 DETERMINATION AND EXTENSION OF CONTRACT TIME..... IV-40

90-08 FAILURE TO COMPLETE ON TIME..... IV-41

90-09 CONTRACT DEFAULT..... IV-42



Alabama State Port Authority
Specification Booklet

Project Name Pinto Cranes Structural Weld Inspection - **REBID**

Location Mobile, Alabama

Project # 11371

Task # 2

JUNE 27, 2024

90-10 CONTRACT TERMINATION	IV-43
SECTION 100 MEASUREMENT AND PAYMENT	IV-44
100-01 MEASUREMENT OF QUANTITIES	IV-44
100-02 SCOPE OF PAYMENT	IV-46
100-03 COMPENSATION FOR ALTERED QUANTITIES	IV-46
100-04 PAYMENT FOR OMITTED ITEMS.....	IV-46
100-05 PAYMENT FOR EXTRA AND FORCE ACCOUNT WORK.....	IV-47
100-06 PARTIAL PAYMENT	IV-48
100-07 PAYMENT FOR MATERIALS ON HAND.....	IV-49
100-08 CONTRACT CLOSE-OUT	IV-50
100-09 WITHHOLDING FOR CLAIMS AND LITIGATION	IV-50
100-10 FINAL PAYMENT	IV-50
100-11 RIGHT OF AUDIT	IV-51



Alabama State Port Authority

Specification Booklet

Project Name Pinto Cranes Structural Weld Inspection - **REBID**

Location Mobile, Alabama

Project # 11371

Task # 2

JUNE 27, 2024

IV-1 | Page

SECTION 10

DEFINITIONS OF TERMS

Whenever the following terms are used in these specifications, in the Contract, in any documents or other instruments pertaining to construction where these specifications govern, the intent and meaning shall be interpreted as follows:

10-01 AASHTO. The American Association of State Highway and Transportation Officials, the successor association of AASHO.

10-02 ACCESS ROAD. The right-of-way, the roadway and all improvements constructed thereon connecting the site of work to a public highway.

10-03 ADVERTISEMENT. A public announcement, as required by local law, inviting bids for work to be performed and materials to be furnished.

10-04 ALDOT SPECS. The State of Alabama Department of Transportation Standard Specifications for Roads and Bridges, latest edition.

10-05 AISC. The American Institute of Steel Construction.

10-06 AREA. American Railway Engineering Association.

10-07 ASA. American Standards Association.

10-08 ASTM. The American Society for Testing and Materials.

10-09 AWARD. The acceptance, by the OWNER, of the successful bidder's proposal.

10-10 AWPI. American Wood Preservers Institute.

10-11 BIDDER. Any individual, partnership, firm or corporation, acting directly or through a duly authorized representative, who submits a proposal for the work contemplated.

10-12 CALENDAR DAY. Every day shown on the calendar.

10-13 CHANGE ORDER. A written order to the Contractor covering changes in the plans, specifications, or proposal quantities and establishing the basis of payment and Contract time adjustment, if any, for the work affected by such changes. The work, covered by a change order, shall be within the scope of the Contract.

10-14 COMMERCE. The prime business of the OWNER, consisting of the transshipping and storage of goods and materials by highway, rail, barge, and ship.

10-15 CONSTRUCTION MANAGER. The individual, partnership, firm or corporation duly authorized by the OWNER to be responsible for construction management supervision of the Contract work and acting directly or through an authorized representative.

10-16 CONTRACT. The written agreement covering the work to be performed. The awarded Contract shall include, but is not limited to: The Advertisement; The Contract Form; The Proposal; The Performance Bond; The Payment Bond; any required insurance certificates; The Specifications; The Plans; Change Orders and any addenda issued to bidders.



Alabama State Port Authority Specification Booklet

Project Name Pinto Cranes Structural Weld Inspection - **REBID**

Location Mobile, Alabama

Project # 11371

Task # 2

JUNE 27, 2024

IV-2 | Page

10-17 CONTRACT ITEM (PAY ITEM). A specific unit of work for which a price is provided in the Contract.

10-18 CONTRACT TIME. The number of calendar days or working days, stated in the special provisions, allowed for completion of the Contract, including authorized time extensions. If a calendar date of completion is stated in the proposal, in lieu of a number of calendar or working days, the Contract shall be completed by that date.

10-19 CONTRACTOR. The individual, partnership, firm or corporation primarily liable for the acceptable performance of the work Contracted and for the payment of all legal debts pertaining to the work who acts directly or through lawful agents or employees to complete the Contract work.

10-20 DEPARTMENT. The Alabama State Port Authority.

10-21 DIRECTOR. The Director of the Alabama State Port Authority, as constituted under the laws of Alabama.

10-22 ENGINEER. The individual, partnership, firm or corporation duly authorized by the OWNER to be responsible for Engineering supervision of the Contract work and acting directly or through an authorized representative.

10-23 EQUIPMENT. All machinery, together with the necessary supplies for upkeep and maintenance, and also all tools and apparatus necessary for the proper construction and acceptable completion of the work.

10-24 EXTRA WORK. An item of work not provided for in the awarded Contract is previously modified by change order or supplemental agreement, but which is found by the Engineer to be necessary to complete the work within the intended scope of the Contract as previously modified.

10-25 FEDERAL SPECIFICATIONS. The Federal Specifications and Standards, and supplements, amendments and indices thereto are prepared and issued by the General Services Administration of the Federal Government. They may be obtained from the Specifications Activity, Printed Materials Supply Division, Building 197, Naval Weapons Plant, Washington D.C. 20407.

10-26 FORCE ACCOUNT. The term used to describe a method of accounting which may be employed as a basis of payment to the Contractor for Extra Work.

10-27 INSPECTOR. An authorized representative of the Engineer assigned to make all necessary reviews of the work performed or being performed, or of the materials furnished or being furnished by the Contractor.

10-28 INTENTION OF TERMS. Whenever, in these specifications or on the plans, the words "directed", "required", "permitted", "ordered", "designated", "prescribed", or words of like import are used, it shall be understood that the direction, requirement, permission, order, designation, or prescription of the Engineer is intended; and similarly, the words "approved", "acceptable" "satisfactory", or words of like import, shall mean approved by, or acceptable to, or satisfactory to the Engineer, subject to each case to the final determination of the OWNER.

Any reference to a specific requirement of a numbered paragraph of the Contract specifications or a cited standard shall be interpreted to include all general requirements of the entire section, specification item, or cited standard that may be pertinent to such specific reference.



Alabama State Port Authority *Specification Booklet*

Project Name Pinto Cranes Structural Weld Inspection - **REBID**

Location Mobile, Alabama

Project # 11371

Task # 2

JUNE 27, 2024

IV-3 | Page

10-29 LABORATORY. The official testing laboratories of the OWNER or such other laboratories as may be designated by the Engineer.

10-30 MAJOR AND MINOR CONTRACT ITEMS. A major Contract item shall be any item that is listed in the proposal, the total cost of which is equal to or greater than 10 percent of the total amount of the awarded Contract. All other items shall be considered minor Contract items.

10-31 MATERIALS. Any substance specified for use in the construction of the Contract work.

10-32 NOTICE TO PROCEED. A written notice to the Contractor to begin the actual work on a previously agreed to date. If applicable, the Notice to Proceed shall state the date on which the Contract time begins.

10-33 OWNER. The term OWNER shall mean the State of Alabama acting by and through the Alabama State Port Authority.

10-34 PAYMENT BOND. The approved form of security furnished by the Contractor and his surety as a guaranty that he will pay in full all bills and accounts for materials and labor used in the construction of the work.

10-35 PERFORMANCE BOND. The approved form of security furnished by the Contractor and his surety as a guaranty that the Contractor will complete the work in accordance with the terms of the Contract.

10-36 PLANS. The official drawings or exact reproductions, approved by the Engineer, which show the location, character, dimensions and details of the work to be done and which are to be considered as a part of the Contract, supplementary to the specifications.

10-37 PROJECT. The agreed scope of work for accomplishing specific development.

10-38 PROPOSAL. The written offer of the bidder (when submitted on the approved proposal form) to perform the contemplated work and furnish the necessary materials in accordance with the provisions of the plans and specifications.

10-39 PROPOSAL FORM. The approved, prepared form on which the OWNER requires that formal bids be submitted for the work contemplated.

10-40 PROPOSAL GUARANTY. The security furnished with a proposal to guarantee that the bidder will enter into a Contract if his proposal is accepted by the OWNER.

10-41 SPECIAL PROVISIONS. Specific directions and provisions additional to these GENERAL PROVISIONS and to any CONSTRUCTION SPECIFICATIONS setting forth conditions or requirements of construction which are not satisfactorily covered by these GENERAL PROVISIONS or the CONSTRUCTION SPECIFICATIONS. SPECIAL PROVISIONS shall prevail over the GENERAL PROVISIONS and CONSTRUCTION SPECIFICATIONS because they set forth the final Contractual intent as to the matter involved.

10-42 SPECIFICATIONS. A part of the Contract containing the written directions and requirements for completing the Contract work. Standards for specifying materials or testing which are cited in the Contract specifications by reference shall have the same force and effect as if included in the Contract physically.



Alabama State Port Authority Specification Booklet

Project Name Pinto Cranes Structural Weld Inspection - **REBID**

Location Mobile, Alabama

Project # 11371

Task # 2

JUNE 27, 2024

IV-4 | Page

10-43 STATE. The State of Alabama, the Party of the First Part to the Contract, acting by and through the Alabama State Port Authority.

10-44 STRUCTURES. Port facilities such as wharves, piers, dolphins, bridges, culverts, catch basins, inlets, retaining walls, cribbing, storm and sanitary sewer lines, water lines, under drains, electrical ducts, manholes, handholes, lighting fixtures and bases, transformers, flexible and rigid pavements, buildings, vaults, and other man-made features of the port that may be encountered in the work and not otherwise classified herein.

10-45 SUBCONTRACTOR. Any properly qualified individual undertaking the performance of any part of the work under the terms of the Contract, by virtue of an agreement between himself and the Contractor, with the approval of the OWNER.

10-46 SUBGRADE. The soil which forms the pavement foundation.

10-47 SUPERINTENDENT. The Contractor's executive representative who is present on the work site during progress, authorized to receive and fulfill instructions from the Engineer, and who shall supervise and direct the construction.

10-48 SUPPLEMENTAL AGREEMENT. A written agreement between the Contractor and the OWNER covering: (1) work that would increase or decrease the total amount of the awarded Contract by not more than 10 percent; or any major Contract item, by more than 25 percent, such increased or decreased work being within the scope of the originally awarded Contract, or (2) work that is not within the scope of the originally awarded Contract.

10-49 SURETY. The corporate body, licensed under the laws of Alabama, bound with and for the Contractor for the acceptable performance of the Contract and also for the payment of all claims recoverable under the Contract Bonds.

10-50 WORK. The furnishing of all labor, materials, tools, equipment and incidentals necessary or convenient to the Contractor's performance of all duties and obligations imposed by the Contract, plans and specifications.

10-51 WORKING DAY. A working day shall be any day other than a national legal holiday, Saturday, or Sunday, on which the normal working forces of the Contractor may proceed with regular work for at least 6 hours toward completion of the Contract. Unless work is suspended for causes beyond the Contractor's control, Saturdays, Sundays and national holidays on which the Contractor's forces engage in regular work, requiring the presence of an inspector, will be considered as working days.



Alabama State Port Authority

Specification Booklet

Project Name Pinto Cranes Structural Weld Inspection - **REBID**

Location Mobile, Alabama

Project # 11371

Task # 2

JUNE 27, 2024

IV-5 | Page

SECTION 20 PROPOSAL REQUIREMENTS AND CONDITIONS

20-01 PREQUALIFICATION OF BIDDERS

Proposal forms will be issued only to prospective Bidders who are licensed under the terms of the existing State laws. If the applicant is a corporation organized in a state other than Alabama, it shall furnish a certificate from the Secretary of State showing that it is qualified to transact business in Alabama.

20-02 CONTENTS OF PROPOSAL FORMS

The OWNER shall furnish bidders with proposal forms. All papers bound with or attached to the proposal forms are necessary parts and must not be detached. The plans, specifications, and other documents designated in the proposal form shall be considered a part of the proposal whether attached or not.

20-03 ISSUANCE OF PROPOSAL FORMS

The OWNER reserves the right to refuse to issue a proposal form to a prospective bidder should such bidder be in default for any of the following reasons:

- (a) Failure to pay, or satisfactorily settle, all bills due for labor and materials on former Contracts in force with the OWNER.
- (b) Contractor default under previous Contracts with the OWNER.
- (c) Proposal withdrawal or Bid Bond forfeiture on previous project with the OWNER.
- (d) Unsatisfactory work on previous Contract with the OWNER.
- (e) Performance failure of manufacturer's product or materials.

20-04 INTERPRETATION OF ESTIMATED PROPOSAL QUANTITIES

An estimate of quantities of work to be done and materials to be furnished under these specifications is given in the proposal. It is the result of careful calculations and is believed to be correct. It is given only as a basis for comparison of proposals and the award of the Contract. The OWNER does not expressly, or by implication, agree that the actual quantities involved will correspond exactly therewith; nor shall the bidder plead misunderstanding or deception because of such estimates of quantities, or of the character, location or other conditions pertaining to the work. Payment to the Contractor will be made only for the actual quantities of work performed or materials furnished in accordance with the plans and specifications. It is understood that the quantities may be increased or decreased as hereinafter provided in the subsection titled 50-02 ALTERATION OF WORK AND QUANTITIES of Division IV, without in any way invalidating the unit bid prices.

20-05 EXAMINATION OF PLANS, SPECIFICATIONS, AND SITE

The bidder is expected to carefully examine the site of the proposed work, the proposal, plans, specifications, and Contract forms. He shall satisfy himself as to the character, quality, and quantities of work to be performed, materials to be furnished, and as to the requirements of the proposed Contract. The submission of a proposal shall be prima facie evidence that the bidder



Alabama State Port Authority

Specification Booklet

Project Name Pinto Cranes Structural Weld Inspection - **REBID**

Location Mobile, Alabama

Project # 11371

Task # 2

JUNE 27, 2024

IV-6 | Page

has made such examination and is satisfied as to the conditions to be encountered in performing the work and as to the requirements of the proposed Contract, plans, and specifications.

Boring logs and other records of subsurface investigations and tests are available for inspection of bidders. It is understood and agreed that such subsurface information, whether included in the plans, specifications, or otherwise made available to the bidder, was obtained and is intended for the OWNER's design and estimating purposes only. Such information has been made available for the convenience of all bidders. It is further understood and agreed that each bidder is solely responsible for all assumptions, deductions, or conclusions which he may make or obtain from his examination of the boring logs and other records of subsurface investigations and tests that are furnished by the OWNER.

20-06 PREPARATION OF PROPOSAL

The bidder shall submit his proposal on the forms furnished by the OWNER. All blank spaces in the proposal forms must be correctly filled in where indicated for each and every item for which a quantity is given. The bidder shall state the price (written in ink or typed) both in words and numerals for which he proposed to do each pay item furnished in the proposal. The Department will check the gross sum given in the proposal and in case of error or discrepancy, the gross sum obtained by adding the products of the unit prices and the various estimated quantities listed in the proposal shall prevail and this shall be the Contract Bid Price. In case of conflict between words and numerals, the words, unless obviously incorrect, shall govern.

The bidder shall sign his proposal correctly and in ink. If the proposal is made by an individual, his name and post office address must be shown. If made by a partnership, the name and post office address of each member of the partnership must be shown. If made by a corporation the person signing the proposal shall give the name of the State under the laws of which the corporation was chartered and the name, titles, and business address of the president, secretary, and the treasurer. Anyone signing a proposal as an agent shall file evidence of his authority to do so and that the signature is binding upon the firm or corporation.

20-07 IRREGULAR PROPOSALS

Proposals shall be considered irregular for the following reasons:

- (a) If the proposal is on a form other than that furnished by the OWNER, if the OWNER's form is altered, or if any part of the proposal form is detached.
- (b) If there are unauthorized additions, conditional or alternate pay items, or irregularities of any kind which make the proposal incomplete, indefinite, or otherwise ambiguous.
- (c) If the proposal does not contain a unit price for each pay item listed in the proposal, except in the case of authorized alternate pay items, for which the bidder is not required to furnish a unit price.
- (d) If the proposal contains unit prices that are obviously unbalanced.
- (e) If the proposal is not accompanied by the bid bond specified by the OWNER.

The OWNER reserves the right to reject any irregular proposal and the right to waive technicalities if such waiver is in the best interest of the OWNER and conforms to laws and ordinances pertaining to the letting of construction Contracts.



Alabama State Port Authority

Specification Booklet

Project Name Pinto Cranes Structural Weld Inspection - **REBID**

Location Mobile, Alabama

Project # 11371

Task # 2

JUNE 27, 2024

IV-7 | Page

20-08 PROPOSAL GUARANTY

Each separate proposal shall be accompanied by a certified check, or other specified acceptable collateral, in the amount of 5% of the bid price, but not more than \$10,000. Such check, or collateral, shall be made payable to the Alabama State Port Authority.

20-09 DELIVERY OF PROPOSAL

Each proposal submitted shall be placed in a sealed envelope plainly marked on the outside with the project description, Bidder's name and address, Contractor's License number, Contractor's Classification of License, and the time and date of bid opening. When sent by mail, preferably registered, the sealed proposal, marked as indicated above, should be enclosed in an additional envelope. No proposal will be considered unless received at the place specified in the advertisement before the time specified for opening all bids.

Proposals received after the bid opening time shall be returned to the bidder unopened.

20-10 WITHDRAWAL OR REVISION OF PROPOSALS

A bidder may withdraw or revise (by withdrawal of one proposal and submission of another) a proposal provided that the bidder's request for withdrawal is received by the OWNER in writing or by telegram before the time specified for opening bids. Revised proposals must be received at the place specified in the advertisement before the time specified for opening all bids.

20-11 PUBLIC OPENING OF PROPOSALS

Proposals shall be opened, and read, publicly at the time and place specified in the advertisement. Bidders, their authorized agents, and other interested persons are invited to attend.

Proposals that have been withdrawn (by written or telegraphic request) or received after the time specified for opening bids shall be returned to the bidder unopened.

20-12 DISQUALIFICATION OF BIDDERS

A bidder shall be considered disqualified for any of the following reasons:

- (a) Submitting more than one proposal from the same partnership, firm or corporation under the same or different name.
- (b) Evidence of collusion among bidders. Bidders participating in such collusion shall be disqualified as bidders for any future work of the OWNER.
- (c) If the bidder is considered to be in "default" for any reason specified in the paragraph titled ISSUANCE OF PROPOSAL FORMS of this subsection.
- (d) If the bidder has not complied with the provisions of the Laws of the State of Alabama concerning licensing of Contractors.
- (e) If an out-of-state bidder has not qualified with the Secretary of State to do business in Alabama.

20-13 LIQUIDATED DAMAGES – Not Applicable to this Project

Time is an essential element in the Contract. As the prosecution of the Work will inconvenience the terminal and vessel operations it is important that the work be pressed vigorously to



Alabama State Port Authority Specification Booklet

Project Name Pinto Cranes Structural Weld Inspection - **REBID**

Location Mobile, Alabama

Project # 11371

Task # 2

JUNE 27, 2024

IV-8 | Page

completion. Also, the cost to the Department of the administration of the Contract, supervision, inspection, engineering, and in some cases maintenance of detours around or over the work under construction will be increased or decreased as the time occupied in the Work is lengthened or shortened. Therefore, exclusive of Sundays, national holidays, and other exceptions and extensions as detailed elsewhere in these Specifications for each day that the Work remains incomplete after the time specified in the Contract, or additional time that may be allowed by the Engineer for the completion of the work when extra or additional work is ordered by the Engineer, the amount specified in the following schedule shall be paid by the Contractor to the Department as liquidated damages for the loss sustained by the State because of failure of the Contractor to complete the work within the specified time.

SCHEDULE OF LIQUIDATED DAMAGES

<u>Contract Bid Price</u>	<u>Amount of Liquidated Damages per Day</u>
\$100,000 and less	\$ 100.00
More than \$100,000 and less than \$250,000	150.00
\$250,000 and less than \$600,000	200.00
\$600,000 or more	0.033% of Contract Amount

20-14 OWNER PURCHASE OF MATERIALS

20-14.1 In accordance with the State of Alabama Statutes for **Sales Tax exemptions for a State Agency**, it is the intent of this Contract for the Alabama State Port Authority (Owner) to reduce sales tax.

20-14.1.1 The Owner reserves the right to purchase all of the required materials or equipment to be used on this project which will become part of the realty.

20-14.1.2 The cost of the Materials and Equipment which will become part of the realty is to be included in the Bid Price. Sales taxes, which will become part of the realty in accordance with the Alabama Statutes, are not to be included.

20-14.1.3 In order to achieve sales tax exemption and avoid jeopardizing immunity from sales taxes it is essential that the following procedures be followed.

20-14.2 Purchase of Materials or Equipment – Not Applicable to this Project

20-14.2.1 All purchase orders must be executed on the Owner's Purchase Order Letterhead/Form.

20-14.2.2 The purchase order form format is to be designed at the Owner's discretion with the Owner reserving approval rights concerning terms and conditions boilerplate.

20-14.2.3 The Contractor's organization will be designated as an agent of the Owner for Material and Equipment purchases and will provide the names of two individuals in the Organization who will be authorized to purchase on the behalf of the Owner.

20-14.2.4 Purchase Orders are to be numerically sequenced with two executed copies furnished to the Construction Manager, one copy of which will be forwarded to the



Alabama State Port Authority

Specification Booklet

Project Name Pinto Cranes Structural Weld Inspection - **REBID**

Location Mobile, Alabama

Project # 11371

Task # 2

JUNE 27, 2024

IV-9 | Page

Owner by the Construction Manager. If a Construction Manager is not assigned to the project, the copies should go directly to the Owner's Project Manager within the Engineering Services Division.

20-14.2.5 Owner Purchase Orders are invalid for gross amounts less than \$2,000.00. Any materials purchased directly by the Contractor for the project shall be subject to Sales Tax and paid by the Contractor.

20-14.3 Payment of Materials or Equipment – Not Applicable to this Project

20-14.3.1 All payments in connection with the purchase orders generated by Owner's Contractor/Agent will be in the form of a check from the Alabama State Port Authority to the appropriate vendors or suppliers.

20-14.3.2 Check Request Form will be furnished to the Contractor by the Owner. The Check Request Form will be numerically sequenced and accounted for.

20-14.3.3 The Contractor is responsible for preparing the Check Request Form for the Owner's signature.

20-14.3.4 An Invoice Transmittal Form is to be designed by the Contractor with the Owner reserving the right of approval of the Invoice Transmittal Form design. It is a primary requirement that the Invoice Transmittal Form indicate that the Owner is the sole payer for materials or equipment. The Invoice Transmittal Form will be numerically sequenced and accounted for.

20-14.3.5 All Contractor requests for payment for materials and equipment purchased under the provisions of this Article will be forwarded to the Construction Manager under cover of the Invoice Transmittal Form, submitted in duplicate, with one copy retained by the Construction Manager and one copy retained by the Owner. The Invoice Transmittal shall be backed-up with signed receiving or delivery tickets, invoices and prepared Check Request Form plus one (1) additional copy of the Check Request Form which will be kept by the Construction Manager.

20-14.3.6 Upon signature by the Owner of the Check Request Form, a check from the Alabama State Port Authority will be issued directly to the vendor or supplier.

20-14.4 Accounting Procedures – Not Applicable to this Project

20-14.4.1 The Contractor's Schedule of Values shall be broken down into three categories, if requested by Owner, showing Material, Equipment and with the remaining category containing labor, fee, rentals, overhead and other costs on a line item basis.

20-14.4.2 Check Request Forms generated by the Contractor/Agent for the Owner shall be collated on a monthly basis and assembled into a credit amount showing amounts to be deducted from the current Payment Application and Contract Sum.

20-14.4.3 The Contractor's Payment Application will be adjusted on a monthly basis in accordance with the preceding monthly accumulated credit amounts for Owner purchases.

20-14.4.4 Discounts which accrue from Owner payments for prompt payment will accrue as 50% to the Owner and 50% to the Contractor.



Alabama State Port Authority *Specification Booklet*

Project Name Pinto Cranes Structural Weld Inspection - **REBID**

Location Mobile, Alabama

Project # 11371

Task # 2

JUNE 27, 2024

IV-10 | Page

20-14.4.5 Retainage will not be withheld on Owner purchased Materials or Equipment.

20-14.5 Procedures – Not Applicable to this Project

The Contractor shall follow the procedures set forth below, but nothing herein shall be construed to reduce, limit or change the Contractor's overall responsibility for the quality, scheduling, coordination, warranty, overhead, profit or retainage, except as provided in subparagraph 20-14.4.5 of the complete Contract scope of work in accordance with all provisions of the Contract Documents.

20-14.5.1 Procurement of Material Selected by Contractor.

With respect to any materials, equipment or product to be purchased by the Owner, the following procedures shall be followed:

1. Immediately upon notice to proceed or award of Contract, the Contractor in conjunction with the Construction Manger shall develop a list of items to be purchased by the Owner for incorporation into the work.
2. When the type, quantity, and price of each lot of materials, equipment or product to be purchased on a single purchase order have been determined by the Contractor, Contractor shall complete the Owner Purchase Order Form and shall sign the form to certify that the material, equipment or product described on the form complies with the requirements of the Contract Documents. The Owner Purchase Order Form, signed by the Contractor shall be forwarded to the vendor by the Contractor. The total monetary value listed on the Purchase Order Form is the cost limitation established for the Purchase Order.
3. Simultaneously, with the Contractor/Agent's issuance of a purchase order form for major items the Contractor shall then incorporate into his expediting schedule his activities showing purchase time, shop drawing time, submittal approval time, integrated into the updated project schedule and then tied into the activity requiring the purchase material.
4. The supplier shall deliver the material, equipment or product to the Contractor in accordance with the provisions of the purchase order, and as required by the Contract Documents. Upon receipt of the materials the Contractor shall inspect the materials, equipment or product as necessary to verify conformity of the material, equipment or product received with the Owner Purchase Order and with the shipping documents. The Contractor shall provide to the Vendor written certification of receipt, or signed delivery ticket, of Each delivery of material, equipment or product which certification shall fully describe any shortages, defects, damage or non-compliance to the supplier within five days or receipt of Each delivery and shall arrange for the return and replacement of defective, damaged or non-conforming material, equipment or product on behalf of the Owner, in accordance with the provisions of the Contract Documents.



Alabama State Port Authority
Specification Booklet

Project Name Pinto Cranes Structural Weld Inspection - **REBID**

Location Mobile, Alabama

Project # 11371

Task # 2

JUNE 27, 2024

IV-11 | Page

5. The supplier shall submit each invoice along with aforementioned proof of delivery for material, equipment or product procured pursuant to the provisions hereof to the Owner in care of the Contractor/Consignee. The Contractor/Consignee shall verify and certify to the Owner the accuracy and completeness of each invoice submitted by the supplier. Each certified invoice shall be submitted with appropriate Check Request Form no later than the Contractor's next monthly Application for Payment to the Owner.
6. After the Contractor's Application for Payment, along with Check Request Forms including certified supplier invoices and delivery tickets, has been approved for payment in accordance with the provisions of the General Conditions, the Owner shall make direct payments to the supplier, and the amount of each such payment, shall be deducted from the then-unpaid balance of the Contractor's Contract Sum. The amount deducted shall be in accordance with subparagraph 20-14.4.2.

20-14.5.2 Owner-Purchased Materials

Materials used on the Project which are purchased by the Owner will be available at the location specified in the Purchase Order and in accordance with the periodically adjusted project schedule. The Contractor shall review the updated and adjusted project schedule and will be responsible for coordinating the deliveries with the progress of the work. The Contractor's costs for storing, transporting, handling, protecting and installing Owner purchased material shall be included in the Contract Sum and paid for **when such material is installed**. The Contractor shall be responsible for material furnished to it, and shall pay for storage charges incurred as a result of its failure to take delivery of Owner material on the assigned date.

The Contractor shall be liable to the Owner for the cost of replacing or repairing material lost or damaged from any cause whatsoever after receipt by the Contractor or after the Contractor has failed to take delivery after the assigned date. The costs will be deducted from any monies due or to become due to the Contractor, except those amounts covered under any claims payments made under insurance policies furnished by the Owner. In cases where lost or damaged material was not evident at the time such materials were received by the Contractor, the Contractor will be afforded the same protection by the Owner as the Owner has received from the original shipper and manufacturer. The Owner, in addition, agrees to provide the Contractor with all necessary assistance in communicating with the manufacturer of any materials which fail to function properly once installed.

The Contractor is responsible for providing and performance of warranty work in connection with the Owner purchased materials, for the time periods as required by the Contract Documents.

20-14.6 Materials and Equipment Responsibility

20-14.6.1 The General Contractor shall retain as part of his Bid and Fee the following responsibilities for care, custody and control of the Owner purchased Materials and Equipment.



Alabama State Port Authority *Specification Booklet*

Project Name Pinto Cranes Structural Weld Inspection - **REBID**

Location Mobile, Alabama

Project # 11371

Task # 2

JUNE 27, 2024

IV-12 | Page

1. Insure that all Materials and Equipment purchased by the Owner are in complete accordance with the plans and specifications.
2. Shop drawings and submittals.
3. Scheduling.
4. Shipment, receipt, unloading, inspection, storage and handling.
5. Return of damaged Materials and Equipment.
6. Filing of freight claims.
7. Installation as required.
8. Startup and testing as required per specifications.
9. Warranty and maintenance as required per specifications.
10. Training as required per specifications.
11. Spare parts. Special tools and additional stock as required by the specifications.
12. In the event the Contractor orders non-specified, wrong size or dimensioned Material or Equipment it will be his responsibility to replace such at no cost to the Owner.

20-14.7 Project Close-Out – Not Applicable to this Project

The Contractor shall return to the Owner all blank Purchase Order Forms issued, but not used on the project.

(Rev. 3/31/11)



Alabama State Port Authority Specification Booklet

Project Name Pinto Cranes Structural Weld Inspection - **REBID**

Location Mobile, Alabama

Project # 11371

Task # 2

JUNE 27, 2024

IV-13 | Page

SECTION 30

AWARD AND EXECUTION OF CONTRACT

30-01 CONSIDERATION OF PROPOSALS

After the proposals are publicly opened and read, they will be compared on the basis of the summation of the products obtained by multiplying the estimated quantities shown in the proposal by the unit bid prices. If a bidder's proposal contains a discrepancy between unit bid prices written in words and unit bid prices written in numbers, the unit price written in words shall govern.

Until the award of the Contract is made, the OWNER reserves the right to reject a bidder's proposal for any of the following reasons:

- a) If the proposal is irregular as specified in the subsection titled IRREGULAR PROPOSALS of Subsection 20.
- b) If the bidder is disqualified for any of the reasons specified in the subsection titled DISQUALIFICATION OF BIDDERS of Subsection 20.

In addition, until the award of a Contract is made, the OWNER reserves the right to reject any or all proposals; waive technicalities, if such waiver is in the best interest of the OWNER and is in conformance with applicable laws or regulations pertaining to the letting of construction Contracts; advertise for new proposals; or proceed with the work otherwise. All such actions shall promote the OWNER's best interests.

30-02 AWARD OF CONTRACT

The award of a Contract, if it is to be awarded, shall be made within 60 calendar days of the date specified for publicly opening proposals.

Award of the Contract shall be made by the OWNER to the lowest qualified bidder whose proposal conforms to the cited requirements of the OWNER.

30-03 CANCELLATION OF AWARD

The OWNER reserves the right to cancel the award without liability to the bidder, except return of proposal guaranty, at any time before a Contract has been fully executed by all parties and is approved by the OWNER in accordance with the paragraph titled APPROVAL OF CONTRACT of this subsection.

30-04 RETURN OF PROPOSAL GUARANTY

All proposal guaranties, except those of the three lowest bidders, will be returned immediately after the OWNER has made a comparison of bids as hereinbefore specified in the paragraph titled CONSIDERATION OF PROPOSALS of this subsection. Proposal guaranties of the two lowest bidders will be retained by the OWNER until such time as an award is made, at which time, the unsuccessful bidders' proposal guaranty will be returned. The successful bidder's proposal guaranty will be returned as soon as the OWNER receives the contract bonds as specified in the paragraph titled "REQUIREMENTS OF CONTRACT BONDS" of the subsection.



Alabama State Port Authority

Specification Booklet

Project Name Pinto Cranes Structural Weld Inspection - **REBID**

Location Mobile, Alabama

Project # 11371

Task # 2

JUNE 27, 2024

IV-14 | Page

30-05 REQUIREMENTS OF CONTRACT BONDS

In order to insure the faithful performance of each and every condition, stipulation, and requirement of the Contract and to indemnify and save harmless the OWNER from any and all damages, either directly or indirectly, (arising out of any failure to perform same), the successful Bidder to whom the Contract is awarded shall, within ten (10) days from the date of award, furnish at his expense and file with the OWNER an acceptable Surety Bond in an amount equal to one hundred percent (100%) of the Contract Bid Price of the Contract as awarded. Said Bond shall be made on the approved bond form, shall be furnished by a reputable surety company authorized to do business in the State of Alabama, shall be counter-signed by an authorized agent resident in the State who is qualified for the execution of such instruments, and shall be attached thereto power of attorney of the signing agent.

In case of default on the part of the Contractor, all expenses incident to ascertaining and collecting losses suffered by the OWNER under the Bond, including both Engineering and legal services, shall lie against the Contract Bond for Performance of the Work.

In addition thereto, the successful Bidder to whom the Contract is awarded shall, within ten (10) days, furnish at his expense and file with the OWNER an acceptable Surety Bond for Payment of Labor, Materials, and Supplies payable to the OWNER in an amount not less than one hundred percent (100%) of the Contract price with the obligation that the Contractor shall promptly make payment to all persons furnishing him or them with labor, materials, foodstuffs, or supplies for, or in, prosecution of the work including the payment of reasonable attorney's fees, incurred by successful claimants or plaintiffs in suits on said bond.

No surety bonds from any insurance company or bonding company which has a lower rating, in the Best Key Rating Guide, than A will be accepted.

30-06 EXECUTION OF CONTRACT

The successful bidder shall sign (execute) the necessary agreements for entering into the Contract and return such signed Contract to the OWNER, along with the fully executed surety bond or bonds specified in the paragraph titled REQUIREMENT OF CONTRACT BONDS of this subsection, within 10 calendar days from the date mailed or otherwise delivered to the successful bidder.

30-07 APPROVAL OF CONTRACT

Upon receipt of the Contract and Contract bond or bonds that have been executed by the successful bidder, the OWNER shall complete the execution of the Contract and return the fully executed Contract to the Contractor. Delivery of the fully executed Contract to the Contractor shall constitute the OWNER's approval to be bound by the successful bidder's proposal and the terms of the Contract.

30-08 FAILURE TO EXECUTE CONTRACT

Failure of the successful bidder to execute the Contract and furnish an acceptable surety bond or bonds within the 10 calendar day period specified in the paragraph titled "REQUIREMENTS OF CONTRACT BONDS" of this subsection shall be just cause for cancellation of the award and forfeiture of the proposal guaranty, not as a penalty, but as liquidation of damages to the OWNER.



Alabama State Port Authority ***Specification Booklet***

Project Name Pinto Cranes Structural Weld Inspection - **REBID**

Location Mobile, Alabama

Project # 11371

Task # 2

JUNE 27, 2024

IV-15 | Page

Award may then be made to the next lowest qualified Bidder or the work may be re-advertised, or otherwise contracted as the Director may decide.



Alabama State Port Authority

Specification Booklet

Project Name Pinto Cranes Structural Weld Inspection - **REBID**

Location Mobile, Alabama

Project # 11371

Task # 2

JUNE 27, 2024

IV-16 | Page

SECTION 40 INDEMNIFICATION AND INSURANCE REQUIREMENTS

40-01 INDEMNIFICATION

The Contractor shall assume all liability for and shall indemnify and save harmless the State of Alabama, the Alabama State Port Authority and its officers and employees, and Engineer from all damages and liability for injury to any person or persons, and injury to or destruction of property, including the loss of use thereof, by reason of an accident or occurrence arising from operations under the Contract, whether such operations are performed by himself or by any subcontractor or by anyone directly or indirectly employed by either of them, occurring on or about the premises, or the ways and means adjacent, during the term of the Contract, or any extension thereof, and shall also assume the liability for injury and/or damages to adjacent or neighboring property by reason of work done under the Contract.

40-02 CONTRACTOR COVERAGE

The Contractor shall not commence work under the Contract until he has obtained all insurance required under the following paragraphs and until such insurance has been approved by the Owner, nor shall the Contractor allow any subcontractor to commence work on his subcontract until all similar applicable insurance required of the subcontractor has been obtained and approved. If the subcontractor does not take out insurance in his own name, then the principal Contractor shall provide such insurance protection for subcontractor and his employees by endorsement to the Contractor's policies or by taking out separate policies in the name of the subcontractor.

40-03 COMMERCIAL GENERAL LIABILITY

The Contractor shall take out and maintain during the life of the Contract Commercial General Liability insurance, including Blanket Contractual and Completed Operations coverage, in an amount not less than \$15,000,000 for any one occurrence for bodily injury, including death, and property damage liability. Policy shall include endorsement identifying the Owner and Engineer as Primary and Non-contributory Additional Insureds as respects the Contractor's work for the Owner, to the extent required by written Contract, including a waiver of all rights of subrogation.

40-04 OWNER'S AND CONTRACTOR'S PROTECTIVE LIABILITY

The Contractor shall take out and maintain during the life of the Contract a separate Owner's and Contractor's Protective Liability policy in the names of the Owner and Engineer in an amount not less than \$2,000,000. Policy shall be delivered to the Owner.

40-05 BUSINESS AUTOMOBILE LIABILITY

The Contractor shall take out and maintain during the life of the Contract Business Automobile Liability insurance covering owned, non-owned and hired vehicles in an amount not less than \$1,000,000 for any one occurrence for bodily injury, including death, and property damage liability. The Owner and Engineer shall be identified as Additional Insureds, to the extent required by written Contract.



Alabama State Port Authority

Specification Booklet

Project Name Pinto Cranes Structural Weld Inspection - **REBID**

Location Mobile, Alabama

Project # 11371

Task # 2

JUNE 27, 2024

IV-17 | Page

40-06 WORKERS COMPENSATION

The Contractor shall take out and maintain during the life of the Contract Workers Compensation and Employers Liability insurance providing coverage under the Alabama Workers Compensation Act in an amount not less than that required by Alabama Law.

Where applicable, Contractor shall take out and maintain during the life of the Contract insurance providing coverage as required by Federal statute, including but not limited to U.S. Longshoremen and Harbor Workers Act (USL&H), Jones Act, and Railroad Federal Employers Liability Act (FELA).

40-07 OCEAN MARINE COVERAGE

In the event work involves the use of watercraft in the completion of the Contract, the Contractor shall provide Protection and Indemnity coverage, including crew, in an amount not less than \$2,000,000 for each loss.

Only the Contractor and/or Subcontractor using watercraft in the completion of its work shall be required to provide evidence of this coverage. In the event the Contractor subcontracts for this portion of the work, the Contractor shall not allow the subcontractor to commence work until such coverage has first been obtained by the subcontractor and approved by the Owner.

40-08 RAILROAD PROTECTIVE LIABILITY

In any case where the Contract involves work within 50 feet of an operating railroad track, the Contractor shall provide a Railroad Protective Liability policy in the name of the railroad whose right of way is involved. The limits of the policy shall be not less than \$2,000,000 per occurrence with \$6,000,000 aggregate.

NOTE #1: With the written approval of the Owner, in lieu of the Railroad Protective Liability policy, the Contractor may cause to be attached to its Commercial General Liability policy standard ISO endorsement, "Contractual Liability – Railroads" (CG 24 17). The railroad must be identified as an Additional Insured.

NOTE #2: Only the Contractor and/or Subcontractor performing the work within 50 feet of the railroad track shall be required to provide evidence of this coverage. In the event the Contractor subcontracts for this portion of the work, the Contractor shall not allow the subcontractor to commence work until such coverage has first been obtained by the subcontractor and approved by the Owner.

40-09 BUILDER'S RISK or INSTALLATION FLOATER

The Contractor shall take out and maintain during the life of the Contract Builder's Risk insurance or Installation Floater, written on an "All Risk" basis, insuring the work included in the Contract against all physical loss. The amount of insurance shall at all times be at least equal to the amount of the Contract. The policy shall be in the names of the Owner, Engineer, Contractor and "all Subcontractors," as their interests appear. Policy shall be provided to the Owner prior to commencement of work.

When changes in scope of work by written Change Order or aggregate Change Orders equal 15 percent of the total Contract, the amount of coverage provided in the Builder's Risk/Installation Floater policy shall be increased accordingly and evidence of increased coverage delivered to the Owner.



Alabama State Port Authority

Specification Booklet

Project Name Pinto Cranes Structural Weld Inspection - **REBID**

Location Mobile, Alabama

Project # 11371

Task # 2

JUNE 27, 2024

IV-18 | Page

40-10 PROFESSIONAL LIABILITY COVERAGE

The Contractor shall take out and maintain during the life of the contract Professional Liability insurance including design with limits not less than \$2,000,000 per occurrence.

40-11 PROOF OF CARRIAGE OF INSURANCE

The Contractor shall furnish to the Owner, in triplicate, Certificates of Insurance, signed by the licensed agent, evidencing the required coverage, along with letter of transmittal giving date of delivery. A copy of this letter shall also be delivered to the Engineer. The Owner reserves the right to require certified copies of any and all policies.

All coverage and bonds shall be provided by companies acceptable to the Owner. Each policy of insurance shall provide, either in body of the policy or by endorsement, that such policy cannot be substantially altered or cancelled without thirty (30) days' written notice to the Owner and insured.

(Rev. 1/26/06)

SECTION 50

SCOPE OF WORK

50-01 INTENT OF CONTRACT

The intent of the Contract is to provide for construction and completion, in every detail, of the work described. It is further intended that the Contractor shall furnish all labor, materials, equipment, tools, transportation, and supplies required to complete the work in accordance with the plans, drawings, specifications, and terms of the Contract.

50-02 ALTERATION OF WORK AND QUANTITIES

The OWNER reserves and shall have the right to make such alterations in the work as may be necessary or desirable to complete the work originally intended in an acceptable manner. Unless otherwise specified herein, the Engineer shall be and is hereby authorized to make such alterations in the work as may increase or decrease the originally awarded Contract quantities, provided that the aggregate of such alterations does not change the total Contract cost by more than 10% or the total cost of any major Contract item by more than 25 percent (total cost being based on the unit prices and estimated quantities in the awarded Contract). Alterations which do not exceed the 25 percent limitation shall not invalidate the Contract nor release the surety, and the Contractor agrees to accept payment for such alteration as if the altered work had been a part of the original Contract. These alterations, which are for work within the general scope of the Contract shall be covered by "Change Orders" issued by the Engineer. Change orders for altered work shall include extensions of Contract time where, in the Engineer's opinion, such extensions are commensurate with the amount and difficulty of added work.

Should the aggregate amount of altered work exceed the 25 percent limitation hereinbefore specified, such excess altered work shall be covered by supplemental agreement. If the OWNER and the Contractor are unable to agree on a unit adjustment for any Contract item that requires a



Alabama State Port Authority

Specification Booklet

Project Name Pinto Cranes Structural Weld Inspection - **REBID**

Location Mobile, Alabama

Project # 11371

Task # 2

JUNE 27, 2024

IV-19 | Page

supplemental agreement, the OWNER reserves the right to terminate the Contract with respect to the item and make other arrangement for its completion.

All supplemental agreements shall require consent of the Contractor's surety and separate performance and payment bonds.

50-03 OMITTED ITEMS

The Engineer may, in the OWNER's best interest, omit from the work any Contract item, except major Contract items. Major Contract items may be omitted by a supplemental agreement. Such omission of Contract items shall not invalidate any other Contract provision or requirement.

Should a Contract item be omitted or otherwise ordered to be non-performed, the Contractor shall be paid for all work performed toward completion of such item prior to the date of the order to omit such item. Payment for work performed shall be in accordance with the paragraph titled PAYMENT FOR OMITTED ITEMS of Subsection 100.

50-04 EXTRA WORK

Should acceptable completion of the Contract require the Contractor to perform an item of work for which no basis of payment has been provided in the original Contract or previously issued change orders or supplemental agreements, the same shall be called Extra Work. Extra work that is within the general scope of the Contract shall contain agreed unit prices for performing the change order work in accordance with the requirements specified in the order, and shall contain any adjustment to the Contract time that, in the Engineer's opinion, is necessary for completion of such extra work.

When determined by the Engineer to be in the OWNER's best interest, he may order the Contractor to proceed with extra work by force account as provided in the paragraph titled PAYMENT FOR EXTRA AND FORCE ACCOUNT WORK of Subsection 100.

Extra work that is necessary for acceptable completion of the project, but is not within the general scope of the work covered by the original Contract shall be covered by a Supplemental Agreement as hereinbefore defined in the paragraph titled SUPPLEMENTAL AGREEMENT of Subsection 10.

Any claim for payment of extra work that is not covered by written agreement (change order or supplemental agreement) shall be rejected by the OWNER.

50-05 MAINTENANCE OF COMMERCE

It is the explicit intention of the Contract that the safety of workers and vessels, as well as the Contractor's equipment and personnel, is the most important consideration.

It is understood and agreed that the Contractor shall provide for the free and unobstructed movement of vessels in the waterfront areas of the port with respect to his own operations and the operations of all his Subcontractors as specified in the paragraph titled LIMITATION OF OPERATIONS of Subsection 90.

With respect to his own operations and the operations of all his Subcontractors, the Contractor shall provide marking, lighting, and other acceptable means of identifying: personnel; equipment;



Alabama State Port Authority

Specification Booklet

Project Name Pinto Cranes Structural Weld Inspection - **REBID**

Location Mobile, Alabama

Project # 11371

Task # 2

JUNE 27, 2024

IV-20 | Page

vehicles; storage areas; and any work area or condition that may be hazardous to the operation of fire rescue equipment, or maintenance vehicles at the port.

When the Contract requires the maintenance of vehicular traffic on an existing road, street, or highway during the Contractor's performance of work that is otherwise provided for in the Contract, plans, and specifications, the Contractor shall keep such road, street, or highway open to all traffic and shall provide such maintenance as may be required to accommodate traffic. The Contractor shall furnish, erect, and maintain barricades, warning signs, flagmen, and other traffic control devices in reasonable conformity with the manual of Uniform Traffic Control Devices for Streets and Highway (published by the United States Government Printing Office), unless otherwise specified herein. The Contractor shall also construct and maintain in a safe condition any temporary connections necessary for ingress to and egress from abutting property or intersecting roads, streets or highways.

The Contractor shall make his own estimate of all labor, materials, equipment, and incidentals necessary for providing the maintenance of commerce and vehicular traffic as specified in this subsection.

The cost of maintaining the commerce and vehicular traffic specified in this subsection shall not be measured or paid for directly, but shall be included in the various Contract items.

50-06 REMOVAL OF EXISTING STRUCTURES

All existing structures encountered within the established lines, grades, or grading sections shall be removed by the Contractor, unless such existing structures are otherwise specified to be relocated, adjusted up or down, salvaged, abandoned in place, reused in the work or to remain in place. The cost of removing such existing structures shall not be measured or paid for directly, but shall be included in the various Contract items.

Should the Contractor encounter an existing structure (above or below ground) in the work for which the disposition is not indicated on the plan, the Engineer shall be notified prior to disturbing such structure. The disposition of existing structures so encountered shall be immediately determined by the Engineer in accordance with the provisions of the Contract.

Except as provided in the subsection titled RIGHTS IN AND USE OF MATERIALS FOUND IN THE WORK of this subsection, it is intended that all existing materials or structures that may be encountered (within the lines, grades, or grading sections established for completion of the work) shall be utilized in the work as otherwise provided for in the Contract and shall remain the property of the OWNER when so utilized in the work.

50-07 RIGHTS IN AND USE OF MATERIALS FOUND IN THE WORK

Should the Contractor encounter any material such as (but not restricted to) sand, stone, gravel, slag, or concrete slabs within the established lines, grades, or grading sections, the use of which is intended by the terms of the Contract to be either embankment or waste, he may at his option either:

- (a) Use such material in another Contract item, providing such use is approved by the OWNER and Engineer and is in conformance with the Contract specifications applicable to such use; or



Alabama State Port Authority Specification Booklet

Project Name Pinto Cranes Structural Weld Inspection - **REBID**

Location Mobile, Alabama

Project # 11371

Task # 2

JUNE 27, 2024

IV-21 | Page

- (b) Remove such material from the site, upon written approval of the Engineer; or
- (c) Use such material for his own temporary construction on site; or
- (d) Use such material as intended by the terms of the Contract.

Should the Engineer approve the Contractor's wish to exercise option (a), (b), or (c), the Contractor shall be paid for the excavation or removal of such material at the applicable Contract price. The Contractor shall replace, at his own expense, such removed or excavated material with an agreed equal volume of material that is acceptable for use in constructing embankment, backfills, or otherwise to the extent that such replacement material is needed to complete the Contract work. The Contractor shall not be charged for his use of such material so used in the work or removed from the site.

Should the Engineer approve the Contractor's exercise of option (a), the Contractor shall be paid, at the applicable contact price, for furnishing and installing such material in accordance with requirements of the Contract item in which the material is used.

It is understood and agreed that the Contractor shall make no claim for delays by reason of his exercise of option (a), (b), or (c).

The Contractor shall not excavate, remove, or otherwise disturb any material, structure, or part of a structure which is located outside the lines, grades, or grading sections established for the work, except where such excavation or removal is provided for in the Contract, plans, or specifications.

50-08 FINAL CLEANING UP

Upon completion of the work and before acceptance and final payment will be made, the Contractor shall remove from the site all machinery, equipment, surplus and discarded materials, rubbish, temporary structures, and stumps or portions of trees. He shall cut all brush and woods within the limits indicated and shall leave the site in a neat and presentable condition. Material cleared from the site and deposited on adjacent property will not be considered as having been disposed of satisfactorily, unless the Contractor has obtained the written permission of such property OWNER.



Alabama State Port Authority

Specification Booklet

Project Name Pinto Cranes Structural Weld Inspection - **REBID**

Location Mobile, Alabama

Project # 11371

Task # 2

JUNE 27, 2024

IV-22 | Page

SECTION 60

CONTROL OF WORK

60-01 AUTHORITY OF THE ENGINEER

The Engineer shall decide any and all questions which may arise as to the quality and acceptability of materials furnished, work performed, and as to the manner of performance and rate of progress of the work. He shall decide all questions which may arise as to the interpretation of the specifications or plans relating to the work, the fulfillment of the Contract on the part of the Contractor, and the rights of different Contractors on the project. The Engineer shall determine the amount and quality of the several kinds of work performed and materials furnished which are to be paid for under the Contract.

60-02 CONFORMITY WITH PLANS AND SPECIFICATIONS

All work and all materials furnished shall be in reasonably close conformity with the lines, grades, grading sections, cross sections, dimensions, material requirements, and testing requirements that are specified (including specified tolerances) in the Contract, plans, or specifications.

If the Engineer finds the materials furnished, work performed, or the finished product not within reasonably close conformity with the plans and specifications but that the portion of the work affected will, in his opinion, result in a finished product having a level of economy, durability, and workmanship acceptable to the OWNER, he will advise the OWNER of his determination that the affected work be accepted and remain in place.

In this event, the Engineer will document his determination and recommend to the OWNER a basis of acceptance which will provide for an adjustment in the Contract price for the affected portion of the work. The Engineer's determination and recommended Contract price adjustments will be based on good Engineering judgment and such tests or retests of the affected work as are, in his opinion, needed. Changes in the Contract price shall be covered by Contract modifications (change order or supplemental agreement) as applicable.

If the Engineer finds the materials furnished, work performed, or the finished product are not in reasonably close conformity with the plans and specifications and have resulted in an unacceptable finished product, the affected work or materials shall be removed and replaced or otherwise corrected by any at the expense of the Contractor in accordance with the Engineer's written orders.

For the purpose of this subsection, the term "reasonably close conformity" shall not be construed as waiving the Contractor's responsibility to complete the work in accordance with the Contract, plans and specifications. The term shall not be construed as waiving the Engineer's right to insist on strict compliance with the requirements of the Contract, plans, and specifications during the Contractor's prosecution of the work, when, in the Engineer's opinion, such compliance is essential to provide an acceptable finished portion of the work.

For the purpose of this subsection, the term "reasonably close conformity" is also intended to provide the Engineer with the authority to use good Engineering judgment in his determinations as to acceptance of work that is not in strict conformity but will provide a finished product equal to or better than that intended by the requirements of the Contract, plans and specifications.



Alabama State Port Authority

Specification Booklet

Project Name Pinto Cranes Structural Weld Inspection - **REBID**

Location Mobile, Alabama

Project # 11371

Task # 2

JUNE 27, 2024

IV-23 | Page

60-03 COORDINATION OF CONTRACT, PLANS AND SPECIFICATIONS

The Contract, plans, specifications, and all referenced standards cited are essential parts of the Contract requirements. A requirement occurring in one is as binding as though occurring in all. They are intended to be complementary and to describe and provide for a complete work. In case of discrepancy, calculated dimensions will govern over scaled dimensions; special provisions shall govern over plans, Contract construction specifications, Contract general provisions, cited specifications, and cited testing standards; plans shall govern over Contract construction specifications, Contract general provisions, and cited testing standards; Contract construction specification shall govern over Contract general provisions, and cited testing standards; Contract general provisions shall govern over cited testing standards. The Contractor shall not take advantage of any apparent error or omission on the plans or specifications. In the event the Contractor discovers any apparent error or discrepancy, he shall immediately call upon the Engineer for his interpretation and decision, and such decision shall be final.

60-04 COOPERATION OF THE CONTRACTOR

The Contractor will be supplied with five (5) copies each of the plans and specifications. He shall have available on the work at all times, one copy each of the plans and specifications. Additional copies of plans and specifications may be obtained by the Contractor for the cost of reproduction.

The Contractor will give constant attention to the work to facilitate the progress thereof, and he shall cooperate with the Engineer and his inspectors and with other Contractors in every way possible. The Engineer shall allocate the work and designate the sequence of construction in case of controversy between Contractors. The Contractor shall have a competent superintendent on the work at all times who is fully authorized as his agent on the work. The superintendent shall be capable of reading and thoroughly understanding the plans and specifications and shall receive and fulfill instructions from the Engineer or his authorized representative.

60-05 COOPERATION BETWEEN CONTRACTORS

The OWNER reserves the right to Contract for and perform other or additional work on or near the work covered by this Contract.

When separate Contracts are let within the limits of any one project, Each Contractor shall conduct his work so as not to interfere with or hinder the progress or completion of the work being performed by other Contractors. Contractors working on the same project shall cooperate with each other as directed.

Each Contractor involved shall assume all liability, financial or otherwise, in connection with his Contract and shall protect and save harmless the OWNER from any and all damages or claims that may arise because of inconvenience, delays, or loss experienced by him because of the presence and operations or other Contractors working within the limits of the same project.

The Contractor shall arrange his work and shall place and dispose of the materials being used so as not to interfere with the operations of the other Contractors within the limits of the same project. He shall join his work with that of the others in an acceptable manner and shall perform it in proper sequence to that of the others.



Alabama State Port Authority Specification Booklet

Project Name Pinto Cranes Structural Weld Inspection - **REBID**

Location Mobile, Alabama

Project # 11371

Task # 2

JUNE 27, 2024

IV-24 | Page

60-06 CONSTRUCTION LAYOUT AND STAKES

The Engineer will establish horizontal and vertical control only and the Contractor must furnish all additional stakes for the layout and construction of the work. The Engineer will also furnish any additional information, upon request of the Contractor, needed to layout and construct the work. The Contractor shall satisfy himself as to the accuracy of all measurements before constructing any permanent structure and shall not take advantage of any errors which may have been made in laying out the work. Such stakes and markings as the Engineer may set for either his own or the Contractor's guidance shall be scrupulously preserved by the Contractor. In case of negligence on the part of the Contractor, or his employees, resulting in the destruction of such stakes or markings, an amount equal to the cost of replacing the same may be deducted from subsequent estimates due to the Contractor at the discretion of the OWNER.

60-07 AUTOMATICALLY CONTROLLED EQUIPMENT

Whenever batching or mixing plant equipment is required to be operated automatically under the Contract and a breakdown or malfunction of the automatic controls occurs, the equipment may be operated manually or by other methods for a period of 48 hours following the breakdown or malfunction, provided this method of operations will produce results which conform to all other requirements of the Contract.

60-08 AUTHORITY AND DUTIES OF INSPECTORS

Inspectors employed by the OWNER shall be authorized to inspect work done and all materials furnished. Such inspection may extend to all or any part of the work and to the preparation, fabrication, or manufacture of the materials to be used. Inspectors are not authorized to revoke, alter, or waive any provision of the Contract. Inspectors are not authorized to issue instructions contrary to the plans and specifications or to act as foreman for the Contractor.

Inspectors employed by the OWNER are authorized to notify the Contractor or his representatives of any failure of the work or materials to conform to the requirements of the Contract, plans, or specifications and to reject such nonconforming materials in question until such issues can be referred to the Engineer for his decision.

60-09 INSPECTION OF THE WORK

All materials and each part or detail of the work shall be subject to review by the Engineer. The Engineer shall be allowed access to all parts of the work and shall be furnished with such information and assistance by the Contractor as is required to make a complete and detailed inspection.

If the Engineer requests it, the Contractor, at any time before acceptance of the work, shall remove or uncover such portions of the finished work as may be directed.

After examination, the Contractor shall restore said portions of the work to the standard required by the specifications. Should the work thus exposed or examined prove acceptable, the uncovering, or removing, and the replacing of the covering or making good of the parts removed will be paid for as extra work; but should the work so exposed or examined prove unacceptable,



Alabama State Port Authority

Specification Booklet

Project Name Pinto Cranes Structural Weld Inspection - **REBID**

Location Mobile, Alabama

Project # 11371

Task # 2

JUNE 27, 2024

IV-25 | Page

the uncovering, or removing, and the replacing of the covering or making good of the parts removed will be at the Contractor's expense.

Any work done or materials used without supervision or inspection by an authorized representative of the OWNER may be ordered removed and replaced at the Contractor's expense unless the OWNER's representative failed to inspect after having been given reasonable notice in writing that the work was to be performed.

Should the Contract work include relocation, adjustment, or any other modification to existing facilities, not the property of the (Contract) OWNER, authorized representatives of the owners of such facilities shall have the right to inspect such work. Such inspection shall in no sense make any facility owner a party to the Contract, and shall in no way interfere with the rights of the parties to this Contract.

60-10 REMOVAL OF UNACCEPTABLE AND UNAUTHORIZED WORK

All work which does not conform to the requirements of the Contract, plans, and specifications will be considered unacceptable, unless otherwise determined acceptable by the OWNER as provided in the paragraph titled CONFORMITY WITH PLANS AND SPECIFICATIONS of this subsection.

Unacceptable work, whether the result of poor workmanship, use of defective materials, damage through carelessness, or any other cause found to exist prior to the final acceptance of the work, shall be removed immediately and replaced in an acceptable manner in accordance with the provisions of the paragraph titled CONTRACTOR'S RESPONSIBILITY FOR WORK of Subsection 80.

No work shall be done without lines and grades having been established by the Contractor and subsequently approved by the Engineer. Work done contrary to the instructions of the Engineer, work done beyond the lines shown on the plans or as given, except as herein specified, or any extra work done without authority, will be considered as unauthorized and will not be paid for under the provisions of the Contract. Work so done may be ordered removed or replaced at the Contractor's expense.

Upon failure on the part of the Contractor to comply forthwith with any order of the Engineer made under the provisions of this subsection, the Engineer will have authority to cause unacceptable work to be remedied, or removed and replaced, and unauthorized work to be removed, and to deduct the costs (incurred by the OWNER) from any monies due or to become due the Contractor.

60-11 LOAD RESTRICTIONS

The Contractor shall comply with all legal load restrictions in the hauling of materials on public roads beyond the limits of the work. A special permit will not relieve the Contractor of liability for damage which may result from the moving of material or equipment.

The operation of equipment of such weight or so loaded as to cause damage to structures or to any other type of construction will not be permitted. Hauling of materials over the base course or surface course under construction shall be limited as directed. No loads will be permitted on a concrete pavement, base, or structure before the expiration of the curing period. The Contractor



Alabama State Port Authority Specification Booklet

Project Name Pinto Cranes Structural Weld Inspection - **REBID**

Location Mobile, Alabama

Project # 11371

Task # 2

JUNE 27, 2024

IV-26 | Page

shall be responsible for all damage done by his hauling equipment and shall correct such damage at his own expense.

60-12 MAINTENANCE DURING CONSTRUCTION

The Contractor shall maintain the work during construction and until the work is accepted. This maintenance shall constitute continuous and effective work prosecuted day by day, with adequate equipment and forces so that the work is maintained in satisfactory condition at all times.

All costs of maintenance work during construction and before the project is accepted shall be included in the unit prices bid on the various Contract items, and the Contractor will not be paid an additional amount for such work.

60-13 FAILURE TO MAINTAIN THE WORK

Should the Contractor at any time fail to maintain the work as provided in the paragraph titled MAINTENANCE DURING CONSTRUCTION of this subsection, the Engineer shall immediately notify the Contractor of such noncompliance. Such notification shall specify a reasonable time within which the Contractor shall be required to remedy such unsatisfactory maintenance condition. The time specified will give due consideration to the urgency that exists.

Should the Contractor fail to respond to the OWNER's notification, the OWNER may suspend any work necessary for the OWNER to correct such unsatisfactory maintenance condition, depending on the urgency that exists. Any maintenance cost incurred by the OWNER, shall be deducted from monies due or to become due the Contractor.

60-14 PARTIAL ACCEPTANCE

If at any time during the prosecution of the project the Contractor substantially completes a usable unit or portion of the work, the occupancy of which will benefit the OWNER, he may request the Engineer to make final inspection of that unit. If the Engineer finds upon inspection that the unit has been satisfactorily completed in compliance with the Contract, he may accept it as being completed, and the Contractor may be relieved of further responsibility for that unit. Such partial acceptance and beneficial occupancy by the OWNER shall not void or alter any provision of the Contract or warranty.

60-15 FINAL CONSTRUCTION INSPECTION

Whenever the Engineer considers the work provided and contemplated by the Contract is nearing completion, or within ten (10) days after being notified by the Contractor that the work is completed, the Engineer will inspect all the work included in the Contract. If the Engineer finds that the work has not been satisfactorily completed at the time of such inspection, he shall inform the Contractor in writing as to the work to be done or the particular defects to be remedied to place the work in condition satisfactory for Final Construction Inspection. After the work has been satisfactorily completed the Engineer shall make the Final Construction Inspection.

60-16 FINAL ACCEPTANCE

Upon due notice from the Contractor of presumptive completion of the entire project, the Engineer and OWNER will make an inspection. If all construction provided for and contemplated by the Contract is found to be completed in accordance with the Contract, plans and specifications, such



Alabama State Port Authority **Specification Booklet**

Project Name Pinto Cranes Structural Weld Inspection - **REBID**

Location Mobile, Alabama

Project # 11371

Task # 2

JUNE 27, 2024

IV-27 | Page

inspection shall constitute the final inspection. The Engineer shall notify the Contractor in writing of final acceptance as of the date of the final inspection.

If, however, the inspection discloses any work, in whole or in part, as being unsatisfactory, the Engineer will give the Contractor the necessary instructions for correction of same, and the Contractor shall immediately comply with and execute such instructions. Upon correction of the work, another inspection will be made which shall constitute the final inspection, provided the work has been satisfactorily completed. In such event, the OWNER will make the final acceptance and notify the Contractor in writing of this acceptance as of the date of final inspection.

60-17 CLAIMS FOR ADJUSTMENT AND DISPUTES

If for any reason the Contractor deems that additional compensation is due him for work or materials not clearly provided for in the Contract, plans, or specifications or previously authorized as extra work, he shall notify the Engineer in writing of his intention to claim such additional compensation before he begins the work on which he bases the claim. If such notification is not given or the Engineer is not afforded proper opportunity by the Contractor for keeping strict account of actual cost as required, then the Contractor hereby agrees to waive any claim for such additional compensation. Such notice by the Contractor and the fact that the OWNER has kept account of the cost of the work shall not in any way be construed as proving or substantiating the validity of the claim. When the work on which the claim for additional compensation is based has been completed, the Contractor shall, within 10 calendar days, submit his written claim to the Engineer, who will present it to the OWNER for consideration.

Nothing in this subsection shall be construed as a waiver of the Contractor's right to dispute the final payment based on differences in measurements or computations.



Alabama State Port Authority

Specification Booklet

Project Name Pinto Cranes Structural Weld Inspection - **REBID**

Location Mobile, Alabama

Project # 11371

Task # 2

JUNE 27, 2024

IV-28 | Page

SECTION 70

CONTROL OF MATERIALS

70-01 SOURCE OF SUPPLY AND QUALITY REQUIREMENTS

The materials used on the work shall conform to the requirements of the Contract, plans, and specifications. Unless otherwise specified, such materials that are manufactured or processed shall be new (as compared to used or reprocessed).

In order to expedite the inspection and testing of materials, the Contractor shall furnish complete statements to the OWNER as to the origin, composition, and manufacture of all materials to be used in the work. Such statements shall be furnished promptly after execution of the Contract, but, in all cases, prior to delivery of such materials.

At the OWNER's option, materials may be approved at the source of supply before delivery is started. If it is found after trial sources of supply for previously approved materials do not produce specified products, the Contractor shall furnish materials from other sources.

70-02 SAMPLES, TESTS, AND CITED SPECIFICATIONS

All materials used in the work shall be inspected, tested, and approved by the Engineer before incorporation in the work. Any work in which untested materials are used without approval or written permission of the Engineer shall be performed at the Contractor's risk. Materials found to be unacceptable and unauthorized will not be paid for and, if directed by the Engineer, shall be removed at the Contractor's expense. Unless otherwise designated, tests in accordance with the cited standard methods of AASHTO or ASTM which are current on the date of advertisement for bids will be made by and at the expense of the OWNER. Samples will be taken by a qualified representative of the OWNER. All materials being used are subject to inspection, test, or rejection at any time prior to or during incorporation into the work. Copies of all tests will be furnished to the Contractor's representative at his request.

70-03 CERTIFICATION OF COMPLIANCE

The Engineer may permit the use, prior to sampling and testing, of certain materials or assemblies when accompanied by manufacturer's certificates of compliance stating that such materials or assemblies fully comply with the requirements of the Contract. The certificate shall be signed by the manufacturer. Each lot of such materials or assemblies delivered to the work must be accompanied by a certificate of compliance in which the lot is clearly identified.

Materials or assemblies used on the basis of certificates of compliance may be sampled and tested at any time and if found not to be in conformity with Contract requirements will be subject to rejection whether in place or not.

The form and distribution of certificates of compliance shall be as approved by the Engineer.

When a material or assembly is specified by "brand name or equal" and the Contractor elects to furnish the specified "brand name", the Contractor shall be required to furnish the manufacturer's certificate of compliance for each lot of such material or assembly delivered to the work. Such certificate of compliance shall clearly identify Each lot delivered and shall certify as to:

- (a) Conformance to the specified performance, testing, quality or dimensional requirements; and
- (b) Suitability of the material or assembly for the use intended in the Contract work.



Alabama State Port Authority Specification Booklet

Project Name Pinto Cranes Structural Weld Inspection - **REBID**

Location Mobile, Alabama

Project # 11371

Task # 2

JUNE 27, 2024

IV-29 | Page

Should the Contractor propose to furnish an “or equal” material or assembly, he shall furnish the manufacturer's certificates of compliance as hereinbefore described for the specified brand name material or assembly. However, the Engineer shall be the sole judge as to whether the proposed “or equal” is suitable for use in the work.

70-04 PLANT INSPECTION

The Engineer or his authorized representative may inspect, at its source, any specified material or assembly to be used in the work. Manufacturing plants may be inspected from time to time for the purpose of determining compliance with specified manufacturing methods or materials to be used in the work and to obtain samples required for his acceptance of the material or assembly.

Should the Engineer conduct plant inspections, the following conditions shall exist:

- (a) The Engineer shall have the cooperation and assistance of the Contractor and the producer with whom he has contracted the materials.
- (b) The Engineer shall have full entry at all reasonable times to such parts of the plant that concern the manufacture or production of the materials being furnished.
- (c) If required by the Engineer, the Contractor shall arrange for adequate office or working space that may be reasonably needed for conducting plant inspections. Office or working space should be conveniently located with respect to the plant.

It is understood and agreed that the OWNER shall have the right to retest any material which has been tested and approved at the source of supply after it has been delivered to the site. The Engineer shall have the right to reject only material which, when retested, does not meet the requirements of the Contract, plans, or specifications.

70-05 ENGINEER'S FIELD OFFICE AND LABORATORY

When specified and provided for as a Contract item, the Contractor shall furnish a building for the exclusive use of the Engineer as a field office and field testing laboratory. The building shall be furnished and maintained by the Contractor, as specified herein, and shall become property of the Contractor when the Contract work is completed.

70-06 STORAGE OF MATERIALS

Materials shall be stored as to assure the preservation of their quality and fitness for the work. Stored materials, even though approved before storage, may again be located so as to facilitate their prompt inspection. The Contractor shall coordinate the storage of all materials with the Engineer. Materials to be stored on OWNER's property shall not create an obstruction to commerce nor shall they interfere with the free and unobstructed movement of traffic. Unless otherwise shown on the plans, the storage of materials and the location of the Contractor's plant and parked equipment or vehicles shall be as directed by the Engineer. Private property shall not be used for storage purposes without written permission of the owner or lessee of such property. The Contractor shall make all arrangements and bear all expenses for the storage of materials on private property. Upon request, the Contractor shall furnish the Engineer a copy of the property owner's permission.



Alabama State Port Authority Specification Booklet

Project Name Pinto Cranes Structural Weld Inspection - **REBID**

Location Mobile, Alabama

Project # 11371

Task # 2

JUNE 27, 2024

IV-30 | Page

All storage sites on private or owner's property shall be restored to their original condition by the Contractor at his entire expense, except as otherwise agreed to (in writing) by the owner or lessee of the property.

70-07 UNACCEPTABLE MATERIALS

Any material or assembly that does not conform to the requirements of the Contract, plans, or specifications shall be considered unacceptable and shall be rejected. The Contractor shall remove any rejected material or assembly from the site of the work, unless otherwise instructed by the Engineer.

No rejected material or assembly, the defects of which have been corrected by the Contractor, shall be returned to the site of the work until such time as the Engineer has approved its use in the work.

70-08 OWNER-FURNISHED MATERIAL

The Contractor shall furnish all materials required to complete the work, except those specified herein (if any) to be furnished by the OWNER. OWNER-furnished materials shall be made available to the Contractor at the location specified herein.

All cost of handling, transportation from the specified location to the site of work, storage, and installing OWNER-furnished materials shall be included in the unit price bid for the Contract item in which such OWNER-furnished material is used.

After any OWNER-furnished material has been delivered to the location specified, the Contractor shall be responsible for any demurrage, damage, loss, or other deficiencies which may occur during the Contractor's handling, storage, or use of such OWNER-furnished material. The OWNER will deduct from any monies due or to become due the Contractor any cost incurred by the OWNER in making good such loss due to the Contractor's handling, storage, or use of OWNER-furnished materials.

70-09 RECEIVING MATERIALS AND EQUIPMENT

The Contractor shall be responsible for clerical salaries, office space and equipment rental, incidentals to receiving incoming shipments and deliveries of all materials and equipment. All material which must be protected from the elements will be properly and orderly stored in shelters provided by the Contractor. All goods and materials stored out of doors will be properly and orderly supported. The Contractor will be responsible for safeguarding all such goods and materials against loss due to damage and theft.



Alabama State Port Authority Specification Booklet

Project Name Pinto Cranes Structural Weld Inspection - **REBID**

Location Mobile, Alabama

Project # 11371

Task # 2

JUNE 27, 2024

IV-31 | Page

SECTION 80 LEGAL RELATIONS AND RESPONSIBILITY TO PUBLIC

80-01 LAWS TO BE OBSERVED

The Contractor shall keep fully informed of all Federal and State laws, and local ordinances, and regulations and all orders and decrees of bodies or tribunals having any jurisdiction or authority, which in any manner affect those engaged or employed on the work, or which in any way affect the conduct of the work. He shall at all times observe and comply with all such laws, ordinances, regulations, orders, and decrees; and shall protect and indemnify the OWNER and all his officers, agents, or servants against any claim or liability arising from or based on the violation of any such law, ordinance, regulation, order, or decree, whether by himself or his employees.

80-02 PERMITS, LICENSES, AND TAXES

The Contractor shall procure all permits and licenses, pay all charges, fees and taxes, and give all notices necessary and incidental to the due and lawful prosecution of the work.

80-03 PATENTED DEVICES, MATERIALS AND PROCESSES

If the Contractor is required or desires to use any design, device, material, or process covered by letters of patent or copyright, he shall provide for such use by suitable legal agreement with the patentee or owner, or a third party, from any and all claims for infringement by reason of the use of any such patented design, device, materials or process, or any trademark or copyright, and shall indemnify the OWNER for such costs, expenses, and damages which it may be obliged to pay by reason of an infringement, at any time during the prosecution or after the completion of the work.

80-04 RESTORATION OF SURFACES DISTURBED BY OTHERS

The OWNER reserves the right to authorize the construction, reconstruction, or maintenance of any public or private utility service, or a utility service of another government agency at any time during the process of the work. To the extent that such construction, reconstruction, or maintenance has been coordinated with the OWNER, such authorized work (by others) is noted in the plans.

Except as noted on the plans, the Contractor shall not permit any individual, firm, or corporation to excavate or otherwise disturb such utility services or facilities located within the limits of the work without the written permission of the Engineer.

Should the owner of public or private utility service, or a utility service of another government agency be authorized to construct, reconstruct, or maintain such utility service or facility during the process of the work, the Contractor shall cooperate with such owners by arranging and performing the work in this Contract so as to facilitate such construction, reconstruction or maintenance by others whether or not such work by others is noted on the plans. When ordered as extra work by the Engineer, the Contractor shall make all necessary repairs to the work which are due to such authorized work by others, unless otherwise provided for in the Contract, plans, or specifications. It is understood and agreed that the Contractor shall not be entitled to make any claim for damages due to such authorized work by others or for any delay to the work resulting from such authorized work.



Alabama State Port Authority *Specification Booklet*

Project Name Pinto Cranes Structural Weld Inspection - **REBID**

Location Mobile, Alabama

Project # 11371

Task # 2

JUNE 27, 2024

IV-32 | Page

80-05 SANITARY, HEALTH, AND SAFETY PROVISIONS

The Contractor shall provide and maintain in a neat, sanitary condition such accommodations for the use of his employees as may be necessary to comply with the requirements of the State and Local Board of Health, or of other bodies or tribunals having jurisdiction.

Attention is directed to Federal, State, and local laws, rules and regulations concerning construction safety and health standards. The Contractor shall not require any worker to work in surroundings or under conditions which are unsanitary, hazardous, or dangerous to his health or safety.

80-06 PUBLIC CONVENIENCE AND SAFETY

The Contractor shall control his operations and those of his Subcontractors and all suppliers, to assure the least inconvenience to the public. Under all circumstances, safety shall be the most important consideration.

The Contractor shall maintain the free and unobstructed movement of commerce and vehicular traffic with respect to his own operations and those of his Subcontractors and all suppliers in accordance with the paragraph titled MAINTENANCE OF COMMERCE of subsection 50, hereinbefore specified and shall limit such operations for the convenience and safety of the public, as specified in the paragraph titled LIMITATION OF OPERATIONS of subsection 90, hereinafter.

80-07 BARRICADES, WARNING SIGNS, AND HAZARD MARKINGS

The Contractor shall furnish, erect, and maintain all barricades, warning signs, and markings for hazards necessary to protect the public and the work. When used during periods of darkness, such barricades, warning signs and hazard markings shall be suitably illuminated.

For vehicular and pedestrian traffic, the Contractor shall furnish, erect, and maintain barricades, warning signs, lights and other traffic control devices in reasonable conformity with the Manual of Uniform Traffic Control Devices for Streets and Highways (published by the United States Government Printing Office).

The Contractor shall furnish, erect, and maintain markings and associated lighting of open trenches, excavations, temporary stockpiles, and his parked construction equipment that may be hazardous to the operation of emergency fire rescue or maintenance vehicles.

The Contractor shall furnish and erect all barricades, warning signs, and markings for hazards prior to commencing work which requires such erection and shall maintain the barricades, warning signs, and markings for hazards until their dismantling is directed by the Engineer.

Open-flame type lights shall not be permitted.



Alabama State Port Authority Specification Booklet

Project Name Pinto Cranes Structural Weld Inspection - **REBID**

Location Mobile, Alabama

Project # 11371

Task # 2

JUNE 27, 2024

IV-33 | Page

80-08 USE OF EXPLOSIVES

When the use of explosives is necessary for the prosecution of the work, the Contractor shall exercise the utmost care not to endanger life or property, including new work. The Contractor shall be responsible for all damage resulting from the use of explosives.

All explosives shall be stored in a secure manner in compliance with all laws and ordinances, and all such storage places shall be clearly marked. Where no local laws or ordinances apply, storage shall be provided satisfactory to the Engineer and, in general, not closer than 1,000 feet from the work or from any building, road, or other place of human occupancy.

The Contractor shall notify Each property owner and public utility company having structures or facilities in proximity to the site of the work of his intention to use explosives. Such notice shall be given sufficiently in advance to enable them to take such steps as they may deem necessary to protect their property from injury.

80-09 PROTECTION AND RESTORATION OF PROPERTY AND LANDSCAPE

The Contractor shall be responsible for the preservation of all public and private property, and shall protect carefully from disturbance or damage all land monuments and property marks until the Engineer has witnessed or otherwise referenced their location and shall not move them until directed.

The Contractor shall be responsible for all damage or injury to property of any character, during the prosecution of the work, resulting from any act, omission, neglect, or misconduct in his manner or method of executing the work, or at any time due to defective work or materials, and said responsibility will not be released until the project shall have been completed and accepted.

When or where any direct or indirect damage or injury is done to public or private property by or on account of any act, omission, neglect, or misconduct in the execution of the work or in consequence of the nonexecution thereof by the Contractor, he shall restore, at his own expense, such property to a condition similar or equal to that existing before such damage or injury was done, by repairing, rebuilding, or otherwise restoring as may be directed, or he shall make good such damage or injury in any acceptable manner.

80-10 RESPONSIBILITY FOR DAMAGE CLAIMS

The Contractor shall indemnify and save harmless the Engineer and the OWNER and their officers, and employees from all suits, actions, or claims of any character brought because of any injuries or damage received or sustained by any person, persons, or property on account of the operations of the Contractor; or on account of or in consequence of any neglect in safeguarding the work; or because of any act or through use of unacceptable materials in constructing the work; or because of any claims or amount recovered from any infringements of patent, trademark, or copyright; or from any claims or amount arising or recovered under the "Workman's Compensation Act" or any other law, ordinance, order or decree.

Money due the Contractor under and by virtue of his Contract as may be considered necessary by the OWNER for such purpose may be retained for the use of the OWNER or, in case no money is due, his surety may be held until such suit or suits, action or actions, claim or claims for injuries or damages as aforesaid shall have been settled and suitable evidence to that effect furnished to



Alabama State Port Authority Specification Booklet

Project Name Pinto Cranes Structural Weld Inspection - **REBID**

Location Mobile, Alabama

Project # 11371

Task # 2

JUNE 27, 2024

IV-34 | Page

the OWNER, except that money due the Contractor will not be withheld when the Contractor produces satisfactory evidence that he is adequately protected by public liability and property damage insurance.

80-11 THIRD PARTY BENEFICIARY CLAUSE

It is specifically agreed between the parties executing the Contract that it is not intended by any of the provisions of any part of the Contract to create the public or any member thereof a third party beneficiary or to authorize anyone not a party to the Contract to maintain a suit for personal injuries or property damage pursuant to the terms or provisions of the Contract.

80-12 OPENING SECTIONS OF THE WORK FOR OCCUPANCY

Should it be necessary for the Contractor to complete portions of the Contract work for the beneficial occupancy of the OWNER prior to completion of the entire Contract, such "phasing" of the work shall be as specified herein, and indicated on the plans. When so specified, the Contractor shall complete such portions of the work on or before the date specified or as otherwise specified. The Contractor shall make his own estimate of the difficulties involved in arranging his work to permit such beneficial occupancy by the OWNER as described elsewhere in these specifications.

Upon completion of any portion of the work so described, such portion shall be accepted by the OWNER in accordance with the paragraph titled PARTIAL ACCEPTANCE of Subsection 60.

No portion of the work may be opened by the Contractor for use until ordered by the Engineer in writing. Should it become necessary to open a portion of the work to Docks traffic on a temporary or intermittent basis, such openings shall be made when, in the opinion of the Engineer, such portion of the work is in an acceptable condition to support the intended traffic. Temporary or intermittent openings are considered to be inherent in the work and shall not constitute either acceptance of the portion of the work so opened or a waiver of any provision of the Contract. Any damage to the portion of the work so opened that is not attributable to traffic which is permitted by the OWNER shall be repaired by the Contractor at his expense.

The Contractor shall make his own estimate of the inherent difficulties involved in completing the work under the conditions herein described and shall not claim any added compensation by reason of delay or increased cost due to opening a portion of the Contract work.

80-13 CONTRACTOR'S RESPONSIBILITY FOR WORK

Until the Engineer's final written acceptance of the entire completed work excepting only those portions of the work accepted in accordance with the paragraph titled PARTIAL ACCEPTANCE of Subsection 60, the Contractor shall have the charge and care thereof and shall take every precaution against injury or damage to any part due to the action of the elements or from any other cause, whether arising from the execution or from the nonexecution of the work. The Contractor shall rebuild, repair, store, and make good all injuries or damages to any portion of the work occasioned by any of the above causes before final acceptance and shall bear the expense thereof.

If the work is suspended for any cause whatever, the Contractor shall be responsible for the work and shall take such precautions necessary to prevent damage to the work. The Contractor shall



Alabama State Port Authority

Specification Booklet

Project Name Pinto Cranes Structural Weld Inspection - **REBID**

Location Mobile, Alabama

Project # 11371

Task # 2

JUNE 27, 2024

IV-35 | Page

provide for normal drainage and shall erect necessary temporary structures, signs, or other facilities at his expense. During such period of suspension of work, the Contractor shall properly and continuously maintain in an acceptable growing condition all living material in newly established planting, seeding, and sodding, furnished under his Contract, and shall take adequate precautions to protect new tree growth and other important vegetative growth against injury.

80-14 CONTRACTOR'S RESPONSIBILITY FOR UTILITY SERVICE AND FACILITIES OF OTHERS

As provided in the paragraph titled RESTORATION OF SURFACES DISTURBED BY OTHERS of this subsection, the Contractor shall cooperate with the owner of any public or private utility service, or a utility service of another government agency that may be authorized by the OWNER to construct, reconstruct or maintain such utility services or facilities during the progress of the work. In addition, the Contractor shall control his operations to prevent the unscheduled interruption of such utility services and facilities.

To the extent that such public or private utility services, or utility services of another governmental agency are known to exist within the limits of the Contract work, the approximate locations have been indicated on the plans.

It is understood and agreed that the OWNER does not guarantee the accuracy or the completeness of the location information relating to existing utility services, facilities, or structures that may be shown on the plans or encountered in the work. Any inaccuracy or omission in such information shall not relieve the Contractor of his responsibility to protect such existing features from damage or unscheduled interruption of service.

It is further understood and agreed that the Contractor shall, upon execution of the Contract, notify the owners of all utility services or other facilities of his plan of operations. Such notification shall be in writing. In addition to the general written notifications hereinbefore provided, it shall be the responsibility of the Contractor to keep such individual owners advised of changes in his plan of operations that would affect such owners.

Prior to commencing the work in the general vicinity of an existing utility service or facility, the Contractor shall again notify Each such owner of his plan or operation. If, in the Contractor's opinion, the owner's assistance is needed to locate the utility service or facility or the presence of a representative of the owner is desirable to observe the work, such advice should be included in the notification. Such notification shall be given by the most expeditious means to reach the utility owner no later than two normal business days prior to the Contractor's commencement of operations in such general vicinity. The Contractor shall furnish a written summary of the notification to the Engineer.

The Contractor's failure to give the two days' notice hereinabove provided shall be cause for the Engineer to suspend the Contractor's operations in the general vicinity of a utility service or facility.

Where the outside limits of an underground utility service have been located and staked on the ground, the Contractor shall be required to use excavation methods acceptable to the Engineer within three (3) feet of such outside limits at such points as may be required to insure protection from damage due to the Contractor's operations.



Alabama State Port Authority Specification Booklet

Project Name Pinto Cranes Structural Weld Inspection - **REBID**

Location Mobile, Alabama

Project # 11371

Task # 2

JUNE 27, 2024

IV-36 | Page

Should the Contractor damage or interrupt the operations of a utility service or facility by accident or otherwise, he shall immediately notify the proper authority and the Engineer and shall take all reasonable measures to prevent further damage or interruption of service. The Contractor, in such events, shall cooperate with the utility service or facility owner and the Engineer continuously until such damage has been repaired and service restored to the satisfaction of the utility or facility owner.

The Contractor shall bear all costs of damage and restoration of service to any utility service or facility due to his operations whether or not due to negligence or accident. The OWNER reserves the right to deduct such costs from any monies due or which may become due the Contractor, or his surety.

80-15 FURNISHING RIGHTS-OF-WAY

The OWNER will be responsible for furnishing all right-of-ways upon which the work is to be constructed in advance of the Contractor's operations.

80-16 PERSONAL LIABILITY OF PUBLIC OFFICIALS

In carrying out any of the Contract provisions or in exercising any power or authority granted to him by this Contract, there shall be no liability upon the Engineer, his authorized representatives, or any official of the OWNER either personally or as an official of the OWNER. It is understood that in such manner they act solely as agents and representatives of the OWNER.

80-17 NO WAIVER OF LEGAL RIGHTS

Upon completion of the work, the OWNER will expeditiously make final inspection and notify the Contractor of final acceptance. Such final acceptance, however, shall not preclude or stop the OWNER from correcting any measurement, estimate or certificate made before or after completion of the work, nor shall the OWNER be precluded or stopped from recovering from the Contractor or his surety, or both, such overpayment as may be sustained, or by failure on the part of the Contractor to fulfill his obligations under the Contract. A waiver on the part of the OWNER of any breach of any part of the Contract shall not be held to be a waiver of any other or subsequent breach.

The Contractor, without prejudice to the terms of the Contract, shall be liable to the OWNER for latent defects, fraud, or such gross mistakes as may amount to fraud, or as regards the OWNER's rights under any warranty or guaranty.

80-18 ENVIRONMENTAL PROTECTION

The Contractor shall comply with all Federal, State and local laws and regulations controlling pollution of the environment. He shall take necessary precautions to prevent pollution of streams, lakes, ponds, and reservoirs with silt runoff, fuels, oils, bitumens, chemicals, or other harmful materials and to prevent pollution of the atmosphere from particulate and gaseous matter.

80-19 ARCHAEOLOGICAL AND HISTORICAL FINDINGS

Unless otherwise specified in this subsection, the Contractor is advised that the site of the work is not within any property, district, or site, and does not contain any building, structure, or object



Alabama State Port Authority *Specification Booklet*

Project Name Pinto Cranes Structural Weld Inspection - **REBID**

Location Mobile, Alabama

Project # 11371

Task # 2

JUNE 27, 2024

IV-37 | Page

listed in the current National Register of Historic Places published by the United States Department of Interior.

Should the Contractor encounter, during his operations, any building, part of a building, structure, or object which is incongruous with its surroundings, he shall immediately cease operations in that location and notify the Engineer. The Engineer will immediately investigate the Contractor's finding and will direct the Contractor to either resume his operations or to suspend operations as directed.

Should the Engineer order suspension of the Contractor's operations in order to protect an archaeological or historical finding, or order the Contractor to perform extra work, such shall be covered by an appropriate Contract modification (change order or supplemental agreement) as provided in the paragraph titled EXTRA WORK AND FORCE ACCOUNT WORK of Subsection 100. If appropriate, the Contract modification shall include an extension of Contract time in accordance with the paragraph titled DETERMINATION AND EXTENSION OF CONTRACT TIME of Subsection 90.



Alabama State Port Authority

Specification Booklet

Project Name Pinto Cranes Structural Weld Inspection - **REBID**

Location Mobile, Alabama

Project # 11371

Task # 2

JUNE 27, 2024

IV-38 | Page

SECTION 90

PROSECUTION AND PROGRESS

90-01 SUBLETTING OF CONTRACT

The OWNER will not recognize any Subcontractor on the work. The Contractor shall at all times when work is in progress be represented either in person, by a qualified superintendent, or by other designated, qualified representative who is duly authorized to receive and execute orders of the Engineer.

Should the Contractor elect to assign his Contract, said assignment shall be concurred in by the surety, shall be presented for the consideration and approval of the OWNER. In case of approval, the Contractor shall file copies of all Subcontractors with the Engineer.

90-02 NOTICE TO PROCEED

The notice to proceed shall state the date on which it is expected the Contractor will begin the construction and from which date Contract time will be charged. If no such date is stated in the notice to proceed, Contract time will start on the date the notice to proceed is issued. The Contractor shall begin the work to be performed under the Contract within ten (10) days of the date set by the Engineer in the written notice to proceed, but in any event the Contractor shall notify the Engineer at least 24 hours in advance of the time actual construction operations will begin.

90-03 PROSECUTION AND PROGRESS

Unless otherwise specified, the Contractor shall submit his progress schedule for the Engineer's approval within 10 days after the effective day of the notice to proceed. The Contractor's progress schedule, when approved by the Engineer, may be used to establish major construction operations and to check on the progress of the work. The Contractor shall provide sufficient materials, equipment, and labor to guarantee the completion of the project in accordance with the plans and specifications within the time set forth in the contract.

If the Contractor falls significantly behind the submitted schedule, the Contractor shall, upon the Engineer's request, submit a revised schedule for completion of the work within the Contract time and modify his operations to provide such additional materials, equipment, and labor necessary to meet the revised schedule. Should the prosecution of the work be discontinued for any reason, the Contractor shall notify the Engineer at least 24 hours in advance of resuming operations.

90-04 LIMITATION OF OPERATIONS

The Contractor shall control his operations and the operations of his Subcontractors and all suppliers so as to provide for the free and unobstructed movement of commerce in those areas adjacent to the work.

90-05 CHARACTER OF WORKERS, METHODS AND EQUIPMENT

The Contractor shall, at all times, employ sufficient labor and equipment for prosecuting the work to full completion in the manner and time required by the Contract, plans, and specifications.



Alabama State Port Authority

Specification Booklet

Project Name Pinto Cranes Structural Weld Inspection - **REBID**

Location Mobile, Alabama

Project # 11371

Task # 2

JUNE 27, 2024

IV-39 | Page

All workers shall have sufficient skill and experience to perform properly the work assigned to them. Workers engaged in special work or skilled work shall have sufficient experience in such work and in the operation of the equipment required to perform the work satisfactorily.

Any persons employed by the Contractor or by any Subcontractor who, in the opinion of the Engineer, does not perform his work in a proper and skillful manner or is intemperate or disorderly shall, at the written request of the Engineer, be removed forthwith by the Contractor or Subcontractor employing such person, and shall not be employed again in any portion of the work without the approval of the Engineer.

Should the Contractor fail to remove such person or persons or fail to furnish suitable and sufficient personnel for the proper prosecution of the work, the Engineer may suspend the work by written notice until compliance with such orders is ascertained.

All equipment which is proposed to be used on the work shall be of sufficient size and in such mechanical condition as to meet the requirements of the work and to produce a satisfactory quality of work. Equipment used on any portion of the work shall be such that no injury to previously completed work, adjacent property, or existing facilities will result from its use.

When the methods and equipment to be used by the Contractor in accomplishing the work are not prescribed in the Contract, the Contractor is free to use any methods or equipment that will accomplish the work in conformity with the requirements of the Contract, plans and specifications.

When the Contract specifies the use of certain methods and equipment, such methods and equipment shall be used unless others are authorized by the Engineer. If the Contractor desires to use a method or type of equipment other than specified in the Contract, he may request authority from the Engineer to do so. The request shall be in writing and shall include a full description of the methods and equipment proposed and of the reasons for desiring to make the change. If approval is given, it will be on the condition that the Contractor will be fully responsible for producing the work in conformity with Contract requirements. If, after trial use on the substituted methods or equipment, the Engineer determines that the work produced does not meet Contract requirements, the Contractor shall discontinue the use of the substitute method or equipment and shall complete the remaining work with the specified methods and equipment. The Contractor shall remove any deficient work and replace it with work of specified quality or take such other corrective action as the Engineer may direct. No change will be made in basis of payment for the Contract items involved or in Contract time as a result of authorizing a change in methods or equipment under this subsection.

90-06 TEMPORARY SUSPENSION OF THE WORK

The Engineer shall have the authority to suspend the work wholly, or in part, for such period or periods as he may deem necessary, due to unsuitable weather, or such other conditions as are considered unfavorable for the prosecution of the work, or for such time as is necessary due to the failure on the part of the Contractor to carry out orders given or perform any or all provisions of the Contract.

In the event that the Contractor is ordered by the Engineer, in writing, to suspend work for some unforeseen cause not otherwise provided for in the Contract and over which the Contractor has no control, the Contractor may be reimbursed for actual money expended on the work during the period of shutdown. No allowance will be made for anticipated profits. The period of shutdown



Alabama State Port Authority Specification Booklet

Project Name Pinto Cranes Structural Weld Inspection - **REBID**

Location Mobile, Alabama

Project # 11371

Task # 2

JUNE 27, 2024

IV-40 | Page

shall be computed from the effective date of the Engineer's order to suspend work to the effective date of the Engineer's order to resume the work. Claims for such compensation shall be filed with the Engineer within the time period stated in the Engineer's order to resume work. The Contractor shall submit with his claim information substantiating the amount shown on the claim. The Engineer will forward the Contractor's claim to the OWNER for consideration. No provision of this article shall be construed as entitling the Contractor to compensation for delays due to inclement weather, for suspensions made at the request of the Contractor, or for any other delay provided for in the Contract, plans, or specifications.

If it should become necessary to suspend work for an indefinite period, the Contractor shall store all materials in such manner that they will not become an obstruction nor become damaged in any way. He shall take every precaution to prevent damage or deterioration of the work performed and provide for normal drainage of the work. The Contractor shall erect temporary structures where necessary to provide for traffic on, to, or from the site.

90-07 DETERMINATION AND EXTENSION OF CONTRACT TIME

The number of calendar or working days allowed for completion of the work shall be stated in the proposal and Contract and shall be known as the CONTRACT TIME.

Should the CONTRACT TIME require extension for reasons beyond the Contractor's control, it shall be adjusted as follows:

- (a) CONTRACT TIME based on WORKING DAYS shall be calculated weekly by the Engineer. The Engineer will furnish the Contractor a copy of his weekly statement of the number of working days charged against the CONTRACT TIME during the week and the number of working days currently specified for completion of the Contract (the original CONTRACT TIME plus the number of working days, if any, that have been included in approved CHANGE ORDERS, or SUPPLEMENTAL AGREEMENTS covering EXTRA WORK).

The Engineer shall base his weekly statement of CONTRACT TIME charges on the following considerations:

- (1) No time shall be charged for days on which the Contractor is unable to proceed with the principal item of work under construction at the time for at least 6 hours with the normal work force employed on such principal item. Should the normal work force be on a triple shift, 18 hours shall apply. Conditions beyond the Contractor's control such as strikes, lockouts, unusual delays in transportation, temporary suspension of the principal item of work under construction or temporary suspension of the entire work which have been ordered by the Engineer for reasons not the fault of the Contractor, shall not be charged against the CONTRACT TIME.
- (2) The Engineer will not make charges against the CONTRACT TIME prior to the effective date of the notice to proceed.
- (3) The Engineer will begin charges against the CONTRACT TIME on the first working day after the effective date of the notice to proceed.
- (4) The Engineer will not make charges against the CONTRACT TIME after the date of final acceptance as defined in the paragraph titled FINAL ACCEPTANCE of Subsection 60.



Alabama State Port Authority Specification Booklet

Project Name Pinto Cranes Structural Weld Inspection - **REBID**

Location Mobile, Alabama

Project # 11371

Task # 2

JUNE 27, 2024

IV-41 | Page

- (5) The Contractor will be allowed one week in which to file a written protest setting forth his objections to the Engineer's weekly statement. If no objection is filed within such specified time, the weekly statement shall be considered as acceptable to the Contractor.
- (6) The CONTRACT TIME (state in the proposal) is based on the originally estimated quantities as described in the paragraph titled INTERPRETATION OF ESTIMATED PROPOSAL QUANTITIES of Subsection 20. Should the satisfactory completion of the Contract require performance of work in greater quantities than those estimated in the proposal, the CONTRACT TIME shall be increased in the same proportion as the cost of the actually completed quantities bears to the cost of the originally estimated quantities in the proposal. Such increase in CONTRACT TIME shall not consider either the cost of work or the extension of CONTRACT TIME that has been covered by change order or supplemental agreement and shall be made at the time of final payment.
- (b) CONTRACT TIME based on CALENDAR DAYS shall consist of the number of calendar days stated in the Contract counting from the effective date of the notice to proceed and including all Saturdays, Sundays, holidays, and no work days. All calendar days elapsing between the effective dates of the Engineer's orders to suspend and resume all work, due to causes not the fault of the Contract, shall be excluded.

At the time of final payment, the CONTRACT TIME shall be increased in the same proportion as the cost that the actually completed quantities bear to the cost of the originally estimated quantities in the proposal. Such increase in the CONTRACT TIME shall not consider either the cost of work or the extension of CONTRACT TIME that has been covered by a change order or supplemental agreement. Charges against the CONTRACT TIME will cease as of the date of final agreement.

- (c) When the CONTRACT TIME is a specified completion date, it shall be the date on which all Contract work shall be substantially completed.

If the Contractor finds it impossible for reasons beyond his control to complete the work within the Contract time as specified, or as extended in accordance with the provisions of this subsection, he may, at any time prior to the expiration of the CONTRACT TIME as extended, make a written request to the Engineer for an extension of time setting forth the reasons which he believes will justify the granting of his request. The Contractor's plea that insufficient time was specified is not a valid reason for extension of time. If the Engineer finds that the work was delayed because of conditions beyond the control and without the fault of the Contractor, he may extend the time for completion in such amount as the conditions justify. The extended time for completion shall then be in full force and effect, the same as though it were the original time for completion.

90-08 FAILURE TO COMPLETE ON TIME

For each calendar day or working day, as specified in the Contract, that any work remains incomplete after the CONTRACT TIME (including all extensions and adjustments as provided in the paragraph titled DETERMINATION AND EXTENSION OF CONTRACT TIME of this Subsection) the sum specified in the Contract and proposal as liquidated damages will be deducted from any money due or to become due the Contractor or his surety. Such deducted sums shall not be deducted as a penalty but shall be considered as liquidation of a reasonable



Alabama State Port Authority Specification Booklet

Project Name Pinto Cranes Structural Weld Inspection - **REBID**

Location Mobile, Alabama

Project # 11371

Task # 2

JUNE 27, 2024

IV-42 | Page

portion of damages that will be incurred by the OWNER should the Contractor fail to complete the work in the time provided in his Contract.

The Contractor will not be charged with liquidated damages when delay in completion of the work is due to acts of the public enemy, acts of the OWNER, acts of another Contractor in the performance of a Contract with the OWNER, fires, floods, epidemics, quarantine restrictions, strikes, or freight embargoes.

Permitting the Contractor to continue and finish the work or any part of it after the time fixed for its completion, or after the date to which the time for completion may have been extended, will in no way operate as a waiver on the part of the OWNER of any rights under the Contract.

90-09 CONTRACT DEFAULT

The Contractor shall be considered in default of his Contract and such default will be considered as cause for the OWNER to terminate the Contract for any of the following reasons if the Contractor:

- (a) Fails to begin the work under the Contract within the time specified in the "Notice to Proceed"; or
- (b) Fails to perform the work or fails to provide sufficient workers, equipment or materials to assure completion of work in accordance with the terms of the Contract; or
- (c) Performs the work unsuitably or neglects or refuses to remove materials or to perform anew such work as may be rejected as unacceptable and unsuitable; or
- (d) Discontinues the prosecution of the work; or
- (e) Fails to resume work which has been discontinued within a reasonable time after notice to do so; or
- (f) Becomes insolvent or is declared bankrupt, or commits an act of bankruptcy or insolvency; or
- (g) Allows any final judgment to stand against him unsatisfied for a period of 10 days; or
- (h) Makes an assignment for the benefit of creditors; or
- (i) For any other cause whatsoever, fails to carry on the work in an acceptable manner.

Should the Engineer consider the Contractor in default of the Contract for any reason hereinbefore, he shall immediately give written notice to the Contractor and the Contractor's surety as to the reasons for considering the construction in default and the OWNER's intentions to terminate the Contract.

If the Contractor or surety, within a period of 10 days after such notice, does not proceed in accordance therewith, then the OWNER will, upon written notification from the Engineer of the facts of such delay, neglect, or default and the Contractor's failure to comply with such notice, have full power and authority without violating the Contract, to take the prosecution of the work out of the hands of the Contractor. The OWNER may appropriate or use any or all materials and equipment that have been mobilized for use in the work and are acceptable and may enter into an agreement for the completion of said Contract according to the terms and provisions thereof,



Alabama State Port Authority Specification Booklet

Project Name Pinto Cranes Structural Weld Inspection - **REBID**

Location Mobile, Alabama

Project # 11371

Task # 2

JUNE 27, 2024

IV-43 | Page

or use such other methods as in the opinion of the Engineer will be required for the completion of said Contract in an acceptable manner.

All costs and charges incurred by the OWNER, together with the cost of completing the work under Contract, will be deducted from any monies due or which may become due the Contractor. If such expense exceeds the sum which would have been payable under the Contract, then the Contractor and the surety shall be liable and shall pay to the OWNER the amount of such excess.

90-10 CONTRACT TERMINATION

The Owner may terminate the Contract, or any portion hereof, for just cause by written notice to the Contractor.

When the Contract, or any portion thereof, is terminated before completion of all items of work in the Contract, payment will be made for the actual number of units or items of work completed or started. No claims for loss of anticipated profits shall be considered.

Acceptable materials both in quantity and quality obtained or ordered by the Contractor that are not incorporated into the work shall, at the option of the Contractor, be purchased by the Owner at actual cost as shown by receipted bills and actual cost records. Delivery of the materials will be performed as designated by the Engineer.

Termination of the Contract, or a portion thereof, shall neither relieve the Contractor of his responsibilities for the completed work nor relieve his surety of its obligation for and concerning any just claim arising out of the work performed.

The costs incurred by the Contractor for mobilization, if applicable, shall be itemized and presented to the Owner. Rebates and refunds that are applicable shall be itemized, and the amount paid the Contractor shall be adjusted to reflect actual cost as shown by receipted bills and actual cost records.

The cost of demobilization of Contractor's equipment and other items pertaining to the expense of moving off the job site shall be itemized and supported by actual cost records and presented for payment. Demobilization as a percentage of the Contract amount, or portion thereof, shall not be paid.

Reimbursement for organization of the work and overhead expenses (when not otherwise included in the Contract) will be considered, the intent being that an equitable settlement will be made with the Contractor.

All of the above are subject to audit as specified by the Right to Audit, Paragraph 100-11.



Alabama State Port Authority Specification Booklet

Project Name Pinto Cranes Structural Weld Inspection - **REBID**

Location Mobile, Alabama

Project # 11371

Task # 2

JUNE 27, 2024

IV-44 | Page

SECTION 100

MEASUREMENT AND PAYMENT

100-01 MEASUREMENT OF QUANTITIES

All work completed under the Contract will be measured by the Engineer, or his authorized representatives, using United States Customary Units of Measurement.

The method of measurement and computations to be used in determination of quantities of material furnished and of work performed under the Contract will be those methods generally recognized as conforming to good Engineering practice.

Unless otherwise specified, longitudinal measurements for area computations will be made horizontally, and no deductions will be made for individual fixtures (or leave-outs) having an area of 9 square feet or less. Unless otherwise specified, transverse measurements for area computations will be the near dimensions shown on the plans or ordered in writing by the Engineer.

Structures will be measured according to neat lines shown on the plans or as altered to fit field conditions.

Unless otherwise specified, all Contract items which are measured by the Linear Foot such as electrical ducts, conduits, pipe culverts, underdrains, and similar items shall be measured parallel to the base or foundation upon which such items are placed.

In computing volumes of excavation the average end area method or other acceptable methods will be used. Acceptability of another method will be decided by the Engineer.

The thickness of plates and galvanized sheet used in the manufacture of corrugated metal pipe, metal plate pipe culverts and arches, and metal cribbing will be specified and measured in decimal fractions of inches.

The term "ton" will mean the short ton consisting of 2,000 pounds avoirdupois. All materials which are measured or proportioned by weights shall be weighed on accurate, approved scales by competent, qualified personnel at locations designated by the Engineer. If material is shipped by rail, the car weight may be accepted provided that only the actual weight of material is paid for. However, car weights will not be acceptable for materials to be passed through mixing plants. Trucks used to haul materials being paid for by weight shall be weighed empty daily at such times as the Engineer directs, and each truck shall bear the plainly legible identification mark.

Materials to be measured by volume in the hauling vehicle shall be hauled in approved vehicles and measured therein at the point of delivery. Vehicles for this purpose may be of any size or type acceptable to the Engineer, provided that the body is of such shape that the actual contents may be readily and accurately determined. All vehicles shall be loaded to at least their water level capacity and all loads shall be leveled when the vehicles arrive at the point of delivery.

When requested by the Contractor and approved by the OWNER in writing, material specified to be measured by the Cubic Yard may be weighed and such weights will be converted to Cubic Yards for payment purposes. Factors for conversion from weight measurement to volume measurement will be determined by the Engineer and shall be agreed to by the Contractor before such method of measurement of pay quantities is used.



Alabama State Port Authority Specification Booklet

Project Name Pinto Cranes Structural Weld Inspection - **REBID**

Location Mobile, Alabama

Project # 11371

Task # 2

JUNE 27, 2024

IV-45 | Page

Bituminous materials will be measured by the gallon or ton. When measured by volume, such volumes will be measured at 60 degrees F, or will be corrected to the volume at 60 degrees F using ASTM D 1250 for asphalt or ASTM D 633 for tars.

Net certified scale weights or weights based on certified volumes in the case of rail shipments will be used as a basis of measurement, subject to correction when bituminous material has been lost from the car or the distributor, wasted, or otherwise not incorporated in the work.

When bituminous materials are shipped by truck or transport, net certified weights by volume, subject to correction for loss or foaming, may be used for computing quantities.

Lumber will be measured by the thousand feet board measure (M.F.B.M.) actually incorporated in the structure. Measurement will be based on nominal widths and thicknesses and the extreme length of each piece.

The term "Lump Sum" when used as an item of payment will mean complete payment for the work described in the Contract.

When a complete structure or structural unit (in effect, "Lump Sum" work) is specified as the unit of measurement, the unit will be construed to include all necessary fittings and accessories.

Rental of equipment will be measured by time in hours of actual working time and necessary traveling time of the equipment within the limits of the work. Special equipment ordered by the Engineer in connection with force account work will be measured as agreed in the change order or supplemental agreement authorizing such force account work as provided in the paragraph titled PAYMENT FOR EXTRA AND FORCE ACCOUNT WORK of this section.

When standard manufactured items are specified such as fence, wire, plates, rolled shapes, pipe conduit, etc., and these items are identified by gage, unit weight, section dimensions, etc., such identification will be considered to be nominal weights or dimensions. Unless more stringently controlled by tolerances in cited specifications, manufacturing tolerances established by the industries involved will be accepted.

Scales for weighing materials which are required to be proportioned or measured and paid for by weight shall be furnished, erected, and maintained by the Contractor, or by certified permanently installed commercial scales.

Scales shall be accurate within one-half percent of the correct weight throughout the range of use. The Contractor shall have the scales checked under the observation of the inspector before beginning work and at such other times as requested. The intervals shall be uniform in spacing throughout the graduated or marked length of the beam or dial and shall not exceed one tenth of one percent of the nominal rated capacity of the scale, but not less than one pound. The use of spring balances will not be permitted.

Beams, dials, platforms, and other scale equipment shall be so arranged that the operator and inspector can safely and conveniently view them.

Scale installation shall have available, ten standard fifty pound weights for testing the weighing equipment or suitable weights and devices for other approved equipment.

Scales must be tested for accuracy and serviced before use at a new site. Platform scales shall be installed and maintained with the platform level and rigid bulkheads at each end.



Alabama State Port Authority

Specification Booklet

Project Name Pinto Cranes Structural Weld Inspection - **REBID**

Location Mobile, Alabama

Project # 11371

Task # 2

JUNE 27, 2024

IV-46 | Page

Scales “overweighing” (indicating more than correct weight) will not be permitted to operate, and all materials received subsequent to the last previous correct weighing-accuracy-test will be reduced by the percentage of error in excess of one-half of one percent.

In the event inspection reveals the scales have been “underweighing” (indicating less than correct weight) they shall be adjusted and no additional payment to the Contractor will be allowed for materials previously weighed and recorded.

All costs in connection with furnishing, installing, certifying, testing, and maintaining scales; for furnishing check weights and scale house; and for all other items specified in this subsection, for the weighing of materials for proportioning, or payment, shall be included in the unit Contract prices for the various items of the project.

When the estimated quantities for a specific portion of the work are designated as the pay quantities in the Contract, they shall be the final quantities for which payment for such specific portion of the work will be made, unless the dimensions of said portion of the work shown on the plans are revised by the Engineer. If revised dimensions result in an increase or decrease in the quantities of such work, the final quantities for payment will be revised in the amount represented by the authorized changes in the dimensions.

100-02 SCOPE OF PAYMENT

The Contractor shall receive and accept compensation provided for in the Contract as full payment for furnishing all materials, for performing all work under the Contract in a complete and acceptable manner, and for all risk, loss, damage, or expense of whatever character arising out of the nature of the work or the prosecution thereof, subject to the provisions of the paragraph titled NO WAIVER OF LEGAL RIGHTS of Subsection 80.

When the “basis of payment” subsection of a technical specification requires that the Contract price (price bid) include compensation for certain work or material essential to the item, this same work or material will not also be measured for payment under any other Contract item which may appear elsewhere in the Contract, plans, or specifications.

100-03 COMPENSATION FOR ALTERED QUANTITIES

When the accepted quantities of work vary from the quantities in the proposal, the Contractor shall accept as payment in full, so far as Contract items are concerned, payment at the original Contract price for the accepted quantities of work actually completed and accepted. No allowance, except as provided for in the paragraph titled ALTERATION OF WORK AND QUANTITIES of Subsection 50 will be made for any increased expense, loss of expected reimbursement, or loss of anticipated profits suffered or claimed by the Contractor which results directly from such alterations or indirectly from his unbalanced allocation of overhead and profit among the Contract items, or from any other cause.

100-04 PAYMENT FOR OMITTED ITEMS

As specified in the paragraph titled OMITTED ITEMS of Subsection 50, the Engineer shall have the right to omit from the work (order nonperformance) any Contract item, except major Contract items, in the best interest of the OWNER.



Alabama State Port Authority Specification Booklet

Project Name Pinto Cranes Structural Weld Inspection - **REBID**

Location Mobile, Alabama

Project # 11371

Task # 2

JUNE 27, 2024

IV-47 | Page

Should the Engineer omit or order nonperformance of a Contract item or portion of such item from the work, the Contractor shall accept payment in full at the Contract prices for any work actually completed and acceptable prior to the Engineer's order to omit or not perform such Contract item.

Acceptable materials ordered by the Contractor or delivered on the work prior to the date of the OWNER's order will be paid for at the actual cost to the Contractor and shall thereupon become the property of the OWNER.

In addition to the reimbursement hereinbefore provided, the Contractor shall be reimbursed for all actual costs incurred for the purpose of performing the omitted Contract item prior to the date of the Engineer's order. Such additional costs incurred by the Contractor must be directly related to the deleted Contract item and shall be supported by certified statements by the Contractor as to the nature and amount of such costs.

100-05 PAYMENT FOR EXTRA AND FORCE ACCOUNT WORK

Extra work, performed in accordance with the paragraph titled EXTRA WORK of Subsection 50, will be paid for at the Contract prices or agreed prices specified in the change order or supplemental agreement authorizing such extra work. When the change order or supplemental agreement authorizing the extra work requires that it be done by force account, such force account shall be measured and paid for as follows:

- (a) Labor: For all labor (skilled and unskilled) and foremen in direct charge of a specific force account item, the Contractor shall receive the rate of wage (or scale) for every hour that such laborer or foreman is actually engaged in the specified force account work. Such wage (or scale) shall be agreed upon in writing before beginning the work.

The Contractor shall receive the actual costs paid to, or in behalf of, workers by reason of subsistence and travel allowances, health and welfare benefits, pension funds benefits or other benefits, when such amounts are required by collective bargaining agreement or other employment Contract generally applicable to the classes of labor employed on the work.

An amount equal to fifteen percent (15%) of the sum of the above items will also be paid the Contractor.

- (b) Insurance and Taxes: For property damage, liability, and workmen's compensation insurance premiums, unemployment insurance contributions, and social security taxes on the force account work, the Contractor shall receive the actual cost, and to this cost (sum) 5 percent will be added. The Contractor shall furnish satisfactory evidence of the rate or rates paid for such insurance and taxes.
- (c) Materials: For materials accepted by the Engineer and used, the Contractor shall receive the actual cost of such materials delivered on the work, including transportation charges paid by him (exclusive of machinery rentals as hereinafter set forth), to which cost (sum) 10 percent will be added.
- (d) Equipment: For any machinery or special equipment (other than small tools) including fuel and lubricants, plus transportation costs, the use of which has been authorized by the



Alabama State Port Authority

Specification Booklet

Project Name Pinto Cranes Structural Weld Inspection - **REBID**

Location Mobile, Alabama

Project # 11371

Task # 2

JUNE 27, 2024

IV-48 | Page

Engineer, the Contractor shall receive the rental rates agreed upon in writing before such work is begun for the actual time that such equipment is committed to the work.

- (e) Miscellaneous: No additional allowance will be made for general superintendence, the use of small tools, or other costs for which no specific allowance is herein provided.
- (f) Comparison of Records: The Contractor and the Engineer shall compare records of the cost of force account work at the end of each day. Agreement shall be indicated by signature of the Contractor and Engineer or their duly authorized representatives.
- (g) Statements: No payment will be made for work performing on a force account basis until the Contractor has furnished the Engineer with the duplicate itemized statements of the cost of such force account work detailed as follows:
 - (1) Name, classification, date, daily hours, total hours, rate and extension for each laborer and foreman.
 - (2) Designation, dates, daily hours, total hours, rental rate, and extension for each unit of machinery and equipment.
 - (3) Quantities of materials, prices, and extensions.
 - (4) Transportation of materials.
 - (5) Cost of property damage, liability and workmen's compensation insurance premiums, unemployment insurance contributions, and social security tax.

Statements shall be accompanied and supported by receipted invoice for all materials used and transportation charges. However, if materials used on the force account work are not specifically purchased for such work but are taken from the Contractor's stock, then in lieu of the invoices the Contractor shall furnish an affidavit certifying that such materials were taken from his stock, that the quantity claimed, was actually used, and that the price and transportation claimed represent the actual cost provided above shall constitute full compensation for such work.

100-06 PARTIAL PAYMENT

Partial payments will be made once each month as the work progresses. Said payments will be based upon estimates prepared by the Engineer of the value of the work performed and materials complete in place in accordance with the Contract, plans, and specifications. Such partial payments may also include the delivered actual cost of those materials stockpiled and stored in accordance with the subsection titled PAYMENT FOR MATERIALS ON HAND of this subsection.

No partial payment will be made when the amount due the Contractor since the last estimate is less than five hundred dollars.

From the total of the amount determined to be payable on a partial payment, 10 percent of such total amount will be deducted and retained by the OWNER until the final payment is made. The balance (90 percent) of the amount payable, less all previous payments, shall be certified for payment.

When not less than 95% of the work has been completed the Engineer may, at his discretion and without the consent of the surety, prepare an estimate from which will be retained an amount not less than twice the Contract value or estimated cost, whichever is greater, of the work remaining



Alabama State Port Authority

Specification Booklet

Project Name Pinto Cranes Structural Weld Inspection - **REBID**

Location Mobile, Alabama

Project # 11371

Task # 2

JUNE 27, 2024

IV-49 | Page

to be done. The remainder, less all previous payments and deductions, will then be certified for payment to the Contractor.

It is understood and agreed that the Contractor shall not be entitled to demand or receive partial payment based on quantities or work in excess of those provided in the proposal or covered by approved change orders or supplemental agreements, except when such excess quantities have been determined by the Engineer to be a part of the final quantity for the item of work in question.

No partial payment shall bind the OWNER to the acceptance of any materials or work in place as to quality or quantity. All partial payments are subject to correction at the time of final payment as provided in the paragraph titled FINAL PAYMENT of this subsection.

100-07 PAYMENT FOR MATERIALS ON HAND

Partial payments, for projects which do not utilize the OWNER'S tax exempt status, may be made to the extent of the delivered cost of materials to be incorporated in the work, provided that such materials meet the requirements of the Contract, plans, and specifications and are delivered to acceptable sites on the OWNER's property or at other sites in the vicinity that are acceptable to the OWNER. Such delivered costs of stored or stockpiled materials may be included in the next partial payment after the following conditions are met:

- (a) The material has been stored or stockpiled in a manner acceptable to the Engineer at or on an approved site.
- (b) The Contractor has furnished the Engineer with acceptable evidence of the quantity and quality of such stored or stockpiled materials.
- (c) The Contractor has furnished the Engineer with satisfactory evidence that the material and transportation costs have been paid.
- (d) The Contractor has furnished the OWNER legal title (free of liens or encumbrances of any kind) to the material so stored or stockpiled.
- (e) The Contractor has furnished the OWNER evidence that the material so stored or stockpiled is insured against loss by damage to or disappearance of such materials at any time prior to use in the work.

It is understood and agreed that the transfer of title and the OWNER's payment for such stored or stockpiled materials shall in no way relieve the Contractor of his responsibility for furnishing and placing such materials in accordance with the requirements of the Contract, plans, and specifications.

In no case will the amount of partial payments for materials on hand exceed the Contract price for such materials or the Contract price for the Contract item in which the material is intended to be used.

No partial payment will be made for stored or stockpiled living or perishable plant materials.

The Contractor shall bear all costs associated with the partial payment of stored or stockpiled materials in accordance with the provisions of this subsection.



Alabama State Port Authority

Specification Booklet

Project Name Pinto Cranes Structural Weld Inspection - **REBID**

Location Mobile, Alabama

Project # 11371

Task # 2

JUNE 27, 2024

IV-50 | Page

100-08 CONTRACT CLOSE-OUT

Subsequent to the final acceptance of this project by the Engineer, the following requirements must be satisfied by the Contractor before final payment can be made.

- (a) The Contractor must publicly advertise the NOTICE OF COMPLETION furnished by the Engineer in accordance with Title 39, Code of Alabama, 1975.
- (b) The Contractor must execute copies of CONTRACTOR'S AFFIDAVIT OF PAYMENT OF CLAIMS AND DEBTS on the form furnished by the Engineer.
- (c) The Contractor must have his surety execute copies of CONSENT OF SURETY TO FINAL PAYMENT on the form furnished by the Engineer.
- (d) The Contractor must furnish a letter on his letterhead acknowledging that acceptance of final payment by the Contractor constitutes a waiver of all claims, present or future, in connection with this project.
- (e) The Contractor must furnish a written guarantee on his letterhead covering all defects in material and workmanship for a period of one (1) year commencing on the date of final acceptance.
- (f) If any purchased items have been incorporated in the work, the Contractor must furnish a letter on his letterhead assigning those warranties to the OWNER. Copies of said warranties shall be bound in one binder and submitted along with the letter assignment.
- (g) The Contractor must keep track of "as built" information and at the contract closeout provide one complete set of reproducible "as built" covering all earthwork, utility routing, structural, mechanical, and electrical aspects of the work, including wiring schematics.

100-09 WITHHOLDING FOR CLAIMS AND LITIGATION

If at the time of Contract close-out, the project is subject to a claim or the Contractor is involved in litigation concerning the project, the OWNER reserves the right to:

- (a) Refuse to close out the Contract retaining all monies unpaid until such time as all claims are dropped and litigation is resolved, or
- (b) Refuse to close out the Contract, retaining enough money to cover the total of all outstanding claims and amounts claimed by litigation until such time as all claims are dropped and litigation is resolved, or
- (c) Require the Contractor to post a letter of credit to each individual claimant or litigant and satisfactory to the claimant or litigant. Once such letters of credit have been posted and the OWNER is in receipt of written agreement from each individual claimant or litigant, the OWNER will proceed with Contract close-out and release of retainage in the normal manner.

100-10 FINAL PAYMENT

When the Contract work has been accepted in accordance with the requirements of the paragraph titled FINAL ACCEPTANCE of Subsection 60, and the paragraph titled Contract CLOSE-OUT above, the Engineer will prepare the final estimate of the items of work actually performed. The Contractor shall approve the Engineer's final estimate or advise the Engineer of his objections to



Alabama State Port Authority Specification Booklet

Project Name Pinto Cranes Structural Weld Inspection - **REBID**

Location Mobile, Alabama

Project # 11371

Task # 2

JUNE 27, 2024

IV-51 | Page

the final estimate, which are based on disputes in measurements or computations of the final quantities to be paid under the Contract, as amended by change order or supplemental agreement. The Contractor and Engineer shall resolve all disputes (if any) in the measurement and computation of final quantities to be paid within 30 calendar days of the Contractor's receipt of the Engineer's final estimate. If, after such 30-day period, a dispute still exists, the Contractor may approve the Engineer's estimate under protest of the quantities in dispute and such disputed quantities shall be considered by the OWNER as a claim in accordance with the paragraph titled CLAIMS FOR ADJUSTMENT AND DISPUTES of Subsection 60.

After the Contractor has approved, or approved under protest, the Engineer's final estimate, final payment will be processed based on the entire sum, or the undisputed sum in case of approval under protest, determined to be due the Contractor less all previous payments and all amounts to be deducted under the provisions of the Contract.

If the Contractor has filed a claim for additional compensation under the provisions of the paragraph titled CLAIMS FOR ADJUSTMENTS AND DISPUTES of Subsection 60 or under the provisions of this subsection, such claims will be considered by the OWNER in accordance with State laws or ordinances. Upon final adjudication of such claims, any additional payment determined to be due the Contractor will be paid pursuant to a supplemental final estimate.

100-11 RIGHT OF AUDIT

Contractor's records which shall include but not be limited to accounting records (hard copy, as well as computer readable data if it can be made available), written policies and procedures; subcontract files (including proposals of successful and unsuccessful bidders, bid recaps, etc.); original estimates; estimating work sheets; correspondence; change order files (including documentation covering negotiated settlements); backcharge logs and supporting documentation; general ledger entries detailing cash and trade discounts earned, insurance policies, rebates and dividends; and any other supporting evidence deemed necessary by the Owner to substantiate charges related to this Contract (all foregoing hereinafter referred to as "records") shall be open to inspection and subject to audit and/or reproduction by Owner's agent or its authorized representative to the extent necessary to adequately permit evaluation and verification of (a) Contractor compliance with Contract requirements, (b) compliance with Owner's business ethics policies, and (c) compliance with provisions for pricing change orders, payment or claims submitted by the Contractor or any of their payees.

Such audits may require inspection and copying from time to time and at reasonable times and places of any and all information, materials and data of every kind and character, including without limitation, records, books, papers, documents, subscriptions, recordings, agreements, purchase orders, leases, Contracts, commitments, arrangements, notes, daily diaries, superintendent reports, drawings, receipts, vouchers and memoranda, and any and all other agreements, sources of information and matters that may in Owner's judgment have any bearing on or pertain to any matters, rights, duties or obligations under or covered by any Contract Document. Such records subject to audit shall also include, but not be limited to, those records necessary to evaluate and verify direct and indirect costs, (including overhead allocations) as they may apply to costs associated with this Contract.

The Owner or its designee shall be afforded access to all of the Contractor's records, and shall be allowed to interview any of the Contractor's employees, pursuant to the provisions of this article



Alabama State Port Authority ***Specification Booklet***

Project Name Pinto Cranes Structural Weld Inspection - **REBID**

Location Mobile, Alabama

Project # 11371

Task # 2

JUNE 27, 2024

IV-52 | Page

throughout the term of this Contract and for a period of three (3) years after final payment or longer if required by law.

Contractor shall require all subcontractors, insurance agents, and material suppliers (payees) to comply with the provisions of this article by insertion of the requirements hereof in a written Contract agreement between Contractor and payee. Such requirements will also apply to Subcontractors and Sub-Subcontractors, etc. Contractor will cooperate fully and will cause all Related Parties and all of Contractor's subcontractors (including those entering into Lump Sum subcontracts) to cooperate fully in furnishing or in making available to Owner from time to time, whenever requested, in an expeditious manner, any and all such information, materials and data.

Owner's agent or its authorized representative shall have access to the Contractor's facilities, shall have access to the Subcontractor's facilities, shall have access to all necessary records, and shall be provided adequate and appropriate work space, in order to conduct audits in compliance with this article.

If an audit inspection or examination in accordance with this article, discloses overcharges (of any nature) by the Contractor to the Owner in excess of one percent (1%) of the total Contract billings, the actual cost of the Owner's audit shall be reimbursed to the Owner by the Contractor. Any adjustments and/or payments which must be made as a result of any such audit or inspection of the Contractor's invoices and/or records shall be made within a reasonable amount of time (not to exceed 90 days) from presentation of Owner's findings to Contractor.



Alabama Port Authority
Specification Booklet

Project Name APA Pinto Cranes Structural Weld Inspection - **REBID**

Location Mobile, AL

Project # 11371 **Task #** 2 **JUNE 27, 2024**

INSPECTION SPECIFICATIONS

DIVISION V
INDEX

SECTION 01100 – GENERAL PROVISIONS..... 2

1.0 **GENERAL**..... 2

ATTACHMENT A PINTO CRANES STRUCTURAL INSPECTIONS SOW 6



Alabama Port Authority
Specification Booklet

Project Name APA Pinto Cranes Structural Weld Inspection - **REBID**
Location Mobile, AL
Project # 11371 **Task #** 2 **JUNE 27, 2024**

SECTION 01100 – GENERAL PROVISIONS

1.0 GENERAL

- 1.1. The following detail Specifications, taken in conjunction with the Project Documents, Drawings and the General Clauses and applicable Material Specifications, describe the work to be performed by the CONTRACTOR. They amplify and explain certain items in connection with the work, but do not alter the scope of same as described in the General Conditions of the Specifications and Contract form.
- 1.2. All materials used in the work, which are not described specifically, shall be of the best quality that it is customary to employ in construction of the character involved. The following details are not necessarily complete in the description of all items entering into the work but are intended to furnish a basis for acceptance of more important items. Other details shall be consistent with them.
- 1.3. Any detail which may be incomplete or lacking in the plans and specifications shall not constitute claim for extra compensation. Such detail shall be supplied by the CONTRACTOR and submitted to the ENGINEER in advance of its requirement on the job. The true intent of the plans and specifications is to produce a complete working facility and incomplete detail will not abrogate this intent
- 1.4. It is the intent to follow the Drawings and Specifications closely in all details, elevations, dimensions, etc., but it is understood that alterations may be required to conform to local conditions and that such alterations must be of the same character of construction as that specified. Workmanship shall be of the best quality in each class of work.
- 1.5. **Since the work involves the inspection of existing equipment, it is necessary that the CONTRACTOR verify all existing conditions affecting the work whether shown on the drawings or not. The ENGINEER shall be notified of any discrepancies that the CONTRACTOR discovers in the drawings.**
- 1.6. Current (latest) editions of all codes specified shall apply.
- 1.7. Permits and Fees – CONTRACTOR shall obtain all necessary permits, licenses, meters, and inspections required for his work and pay all fees and charges required for execution of this contract. Provide certificates of approval to ENGINEER and APA.



Alabama Port Authority
Specification Booklet

Project Name APA Pinto Cranes Structural Weld Inspection - **REBID**

Location Mobile, AL

Project # 11371 **Task #** 2 **JUNE 27, 2024**

- 1.8. Verification of APA's Data – Prior to and during the work, the CONTRACTOR shall satisfy himself as to the accuracy of all data indicated on the Drawings and/or provided by the APA. Should the CONTRACTOR discover any inaccuracies, errors, or omissions in the data, he shall immediately notify the ENGINEER.
- 1.9. Extent of work is indicated in the Drawings, Schedules, and Specifications. Singular references shall not be construed as requiring only one device if multiple devices are shown on the Drawings or are required for proper system operation.
- 1.10. **The CONTRACTOR acknowledges that this work is to be performed at an existing working facility and as such the CONTRACTOR shall coordinate with the APA and work in conjunction and around the APA's operations – as noted in ATTACHMENT A.**
- 1.11. Definitions:
 - 1.11.1 Provide – Furnish, install, and test, complete and ready for intended use.
 - 1.11.2 Furnish – Supply and deliver to project site, ready for subsequent requirements.
 - 1.11.3 Install – Operations at project site, including providing, unloading, unpacking, assembly, erection, placing, anchoring, applying, working to dimension, finishing, curing, protecting, cleaning, and similar requirements.
 - 1.11.4 Approved – Approved and accepted for construction by the ENGINEER. Any exceptions shall be noted in writing.
 - 1.11.5 Approved Equal – Approved as equivalent in quality and workmanship and will perform satisfactorily according to their intended purpose. The ENGINEER shall approve in writing all such substitutions in materials or equipment.
- 1.12. Requests for Substitution:
 - 1.12.1 Where a particular system, test, product or material is specified by name, consider it as standard basis for bidding, and base proposal on the product or material specified. Other systems, tests, products, equipment or materials may be accepted only if in the opinion of the ENGINEER, they are equivalent in quality and workmanship and will perform



Alabama Port Authority
Specification Booklet

Project Name APA Pinto Cranes Structural Weld Inspection - **REBID**
Location Mobile, AL
Project # 11371 **Task #** 2 **JUNE 27, 2024**

satisfactorily according to their intended purpose. The ENGINEER shall approve all such substitutions in materials, tests or equipment in writing.

1.12.2 In making requests for substitutions, the CONTRACTOR shall list the particular product, test, equipment or material he wishes to substitute and at bid time the CONTRACTOR shall state the amount he will add or deduct from his base bid if the substitution is approved by the ENGINEER. If the CONTRACTOR allows no deduction or addition to the base bid for such substitution, it shall be so stated on the request.

1.12.3 Requests by CONTRACTOR for substitution will be considered only when reasonable, timely, fully documented, and qualifying under one or more of the following circumstances.

- a. Required product or test cannot be supplied in time for compliance with Contract time requirements.
- b. Required product is not acceptable to governing authority, or determined to be non-compatible, or cannot be properly coordinated, warranted or insured, or has other recognized disability as certified by CONTRACTOR.
- c. Substantial cost advantage is offered APA after deducting offsetting disadvantages including delays, additional compensation for redesign, investigation, evaluation and other necessary services and similar considerations.

1.12.4 All requests for substitution shall contain a "Comparison Schedule" and clearly and specifically indicate any and all differences or omissions between the product or test specified as the basis of design and the product or test proposed for substitution. Differences shall include but shall not be limited to data as follows for both the specified and substituted products:

- a. Principle of operation.
- b. Materials of construction or finishes.
- c. Thickness of materials.
- d. Weight of item.
- e. Deleted features or items.



Alabama Port Authority
Specification Booklet

Project Name APA Pinto Cranes Structural Weld Inspection - **REBID**
Location Mobile, AL
Project # 11371 **Task #** 2 **JUNE 27, 2024**

- f. Added features or items.
- g. Changes in other work caused by the substitution.
- h. Performance and rating data.

1.12.5 If the approved substitution contains differences or omissions not specifically called to the attention of the ENGINEER, the APA reserves the right to require equal or similar features to be added to the substituted products at the CONTRACTOR's expense.

1.13. Prior Approval – Where the terms "approved equal" is used in the Drawings or the Specifications, submit all requests for ENGINEER's written approval of the alternate manufacturer's products. Approval will be in the form of an Addendum to the Specifications and Drawings. Clearly indicate all differences between the specified and proposed product following the guidelines for substitution herein. This requirement may be waived if, by the opinion of the ENGINEER, it is for the best interest of the APA.

END OF SECTION



Alabama Port Authority
Specification Booklet

Project Name APA Pinto Cranes Structural Weld Inspection - **REBID**

Location Mobile, AL

Project # 11371

Task # 2

JUNE 27, 2024

ATTACHMENT A

PINTO CRANES

STRUCTURAL

INSPECTIONS -

SCOPE OF WORK



Alabama Port Authority
Specification Booklet

Project Name APA Pinto Cranes Structural Weld Inspection - **REBID**
Location Mobile, AL
Project # 11371 **Task #** 2 **JUNE 27, 2024**

Project Information:

Project Title: APA Pinto Cranes Structural Weld Inspection

Owner: Alabama Port Authority (APA)

APA's Engineer/Representative: APTIM Port Services, LLC (APTIM)

Description of Work: The project consists of NDE structural weld inspections of APA Slab Handling Cranes 1, 2, and 3 located at the Pinto Island Wharf in Mobile, AL. This document is focused on the requirements of the structural weld inspection performed by methods of non-destructive examination (NDE).

- Structural Weld Inspection – Performed by a qualified weld inspection company under the direction and oversight of the owner (APA) and owner's representative (APTIM). Requirements of inspection involve a complete visual (VT), a partial magnetic particle/liquid dye penetrant (MT/PT), a partial bolt inspection (BT) and a partial ultrasonic (UT) structural weld inspection of APA Slab Handling Cranes 1, 2, and 3.
- ET/ACFM is not currently expected to be utilized on this project. Specific locations may be reviewed/considered if proposed by the successful bidder during the project. PT will be considered on a case-by-case basis.

Objective: To perform a complete and thorough visual (VT) inspection of all primary structural welds along with a partial MT/PT and partial UT weld inspection on APA Slab Handling Cranes 1, 2, and 3 in accordance with the bid documents and supplemental information provided.



Alabama Port Authority
Specification Booklet

Project Name APA Pinto Cranes Structural Weld Inspection - **REBID**

Location Mobile, AL

Project # 11371 **Task #** 2

JUNE 27, 2024

Supplemental Information:

The structural weld inspection shall follow the inspection program as described within this document and in accordance with the supplemental information/documents as described below. The final version of these documents will be provided to the selected Contractor.

- Inspection Manual(s) – Provided by APTIM, the inspection manual(s) identify the weld locations and details to be inspected. The manual(s) also describes the method of non-destructive examination (NDE) to be performed and the reporting/documentation procedure required. **Refer to Appendix A for example sheets of the Inspection Manual and Appendix B for example of the weld inspection reporting form.**
- Summary of Inspection Document – Provided by APTIM, the summary of inspection sheet shall be used in combination with the inspection manuals. The summary of inspection document provides a list of each manual page and the corresponding number of required inspection welds/locations. This document is to be used as a tracking sheet for progress. It also provides counts of the various inspection requirements to be used during bidding. **Refer to Appendix C for the summary of Inspection Document.**
- Crane Drawings – Provided by APA, the OEM crane drawings will be available on site to the contractor/weld inspector for use as reference if needed during this project.
- Autodesk Construction Cloud – Build Software (ACC – Build) installed on iPad – APA / APTIM will provide to the Contractor for use on this project two (2) iPads loaded with ACC-Build and the Inspection project. This software platform shall be used to document the inspection result (effectively in real-time).
- Autodesk Construction Cloud – Build Software Guide – Provided by APTIM, this document will provide a short description of the Build software which will be the primary documentation software used for this project. All weld forms will be submitted and tracked in Build by the Contractor.



Alabama Port Authority
Specification Booklet

Project Name APA Pinto Cranes Structural Weld Inspection - **REBID**

Location Mobile, AL

Project # 11371

Task # 2

JUNE 27, 2024

Scope of Work:

Weld Inspector: NDE Scope of Work:

1. APA will secure/engage a qualified and experienced NDE inspection company to perform the structural weld inspection. The weld inspection company shall provide the following:
 - a. Furnishing of all labor (minimum of two certified weld inspectors required to be onsite at all times) and all inspection/testing equipment required to perform/fulfill the structural weld inspection program as identified in the Cranes 1, 2, and 3 structural inspection manuals and as described within the bid documents. APA expects continuity of inspectors throughout the duration of the project. One Crane at a time will be available 8AM to 6PM Monday – Saturday. We expect the inspections will take approximately 3 weeks per crane to complete. Cranes will resume normal overnight operation from 7PM – 7AM each day and as such, the inspector will need to remove all loose equipment from the crane(s) at the end of each work day.
 - b. Prior to the inspectors arrival, APTIM will mark all areas on cranes that need paint removed and APA will clean and remove paint as necessary for the inspectors to be able to perform timely inspections per the requirements of the manual.
 - c. The weld inspectors (Level II minimum) are required to perform a complete visual inspection of all primary structural welds along with additional inspection at all weld locations as identified within the manuals. The inspection requirements at each weld location will be per the summary of inspection document provided by APA/APTIM.
 - d. Weld inspection along with complete and accurate documentation shall be the responsibility of the weld inspector. Requirements and procedures of the inspection shall follow the provided Cranes 1, 2, and 3 structural inspection manuals and summary of inspection document. Inspection results shall be entered into the ACC-Build project as the inspections are completed (real time / daily).
 - e. All weld inspection shall comply with AWS D1.1 latest edition for cyclically loaded structures.



Alabama Port Authority
Specification Booklet

Project Name APA Pinto Cranes Structural Weld Inspection - **REBID**
Location Mobile, AL
Project # 11371 **Task #** 2 **JUNE 27, 2024**

- f. All cleaning, paint removal, potential repair, and repainting will be completed by APA.
- g. APA reserves the right to take back the cranes at any time for use in operation. The contractor will be given 90 minutes to leave the crane and take all equipment with them. (Contractor shall provide an hourly stand-by rate per inspector.)

Structural Weld Inspection Program:

APA will secure an approved (NDE) inspection company to perform the required weld inspection in cooperation with APTIM and the support contractor onsite. The weld inspector shall be responsible to APA for all inspection work, but in general will follow the Structural Inspection Manual documentation created by APTIM and accessible in the Autodesk Construction Cloud software – “Build”. The weld inspector will be assisted by the APA during the inspection as required to facilitate and expedite the work.

Project Notes:

Project Execution:

1. Prior to the inspectors arrival, APTIM will mark all areas on cranes that need paint removed and APA will clean and remove paint as necessary for the inspectors to be able to perform timely inspections per the requirements of the manual.
2. The weld inspector is responsible for execution of the structural NDE weld inspection, documentation of all findings and recording all results in accordance with the procedures as outlined and described in the bid documents, structural inspection manuals and summary of inspection document provided.
3. It is the intent of the structural inspection manuals to identify the locations and welds requiring inspection as well as the inspection procedure/method.
4. APA is responsible for assisting the weld inspector during inspection by providing safe access to all inspection locations and preparing the weld areas for NDE inspection.
 - a. For clarity – safe access to the inspection locations shall be accomplished by a combination of crane access systems, manlift, scaffolding and/or mobile crane man-basket. Much of the work will be performed at heights above 100 feet above



Alabama Port Authority
Specification Booklet

Project Name APA Pinto Cranes Structural Weld Inspection - **REBID**

Location Mobile, AL

Project # 11371

Task # 2

JUNE 27, 2024

ground level. Contractor's inspectors shall be experienced in such inspection environments.

- i. The intent is for the Port to provide all access required to complete the inspection. If there are specific locations that the successful bidder recommends utilizing rope access the Port will review/consider them on a case-by-case basis.
 - b. Preparation for VT inspection will include cleaning the surface of the weld removing all corrosion, oils, dust, grease, etc. as required to allow for unobstructed visual inspection.
 - c. Preparation for MT/PT and UT inspection requires APA to clean the surface of the weld down to sound/bare metal removing all paint, corrosion, oils, dust, grease, etc. as required to allow for MT/PT and UT inspection methods.
5. Reporting – All weld inspection forms will be filled out in the Autodesk Construction Cloud software “Build”. APA will provide the Contractor with two (2) iPads for the duration of the project. This online software will include all reference documentation, the inspection manual and all relevant forms. Forms will be submitted upon completion in Build. Any additional documentation supplied by the contractor will be assigned a new “Issue” and will be reviewed by APA and APTIM. The fillable forms are accessible by using the “Sheet” for each crane. Each “Sheet” will have an “Issue” assigned for each weld inspection area. Each “Issue” will have one or more fillable forms based on how many areas are in the specific component.
6. Revisions - Any minor revisions to the manuals member and location diagrams required to accurately reflect field conditions of the identified welds will be documented by the weld inspector and submitted into Build to be reviewed by APTIM and updated by APTIM as required.
7. Discovery of additional structural welds – It shall be the weld inspector's responsibility to locate, identify, inspect and document each additional weld discovered during the inspection not located or identified in the inspection manuals or summary of inspection document (including splice joints of structural members). The deliverables to APA regarding documentation of the additional welds discovered shall be uploaded to Build and include the following:
 - i. Locate and Identify – The weld inspector shall accurately document (likely by field sketch) the location of each additional weld and assign each additional weld a new Weld ID. At the conclusion of the inspection,



Alabama Port Authority
Specification Booklet

Project Name APA Pinto Cranes Structural Weld Inspection - **REBID**

Location Mobile, AL

Project # 11371

Task # 2

JUNE 27, 2024

the weld inspector shall provide APA and APTIM a sheet or sheets similar to the member and location diagrams locating and identifying each additional weld inspected. These sheets should be uploaded to ACC Build at the same time they are provided to APA and APTIM in an effort to keep the online documentation up to date.

- ii. Type of Inspection – The weld inspector shall identify the inspection method performed. All additional welds discovered on structural members are required to be visually tested (VT); however, in some cases the visual testing may lead to the requirement of additional inspection methods (likely MT and/or UT) being performed.
 - iii. Result of Inspection – The weld inspector shall record the result of the inspection(s) performed. At the conclusion of the inspection, the weld inspector shall provide APA the additional inspection results on an inspection record sheet similar to the inspection sheet provided in the manuals.
8. If a crack or other deficiency is discovered during inspection, the weld inspector will notify APA or the APTIM engineer onsite immediately. APTIM will provide a repair sketch and/or procedure to be executed by APA onsite. Repairs are expected to be performed while the NDE inspection continues in other locations. Any weld repair shall be re-inspected by the weld inspector to ensure the repair was successful.

NDE Inspection Schedule, Timeline, Labor, and Equipment:

1. The NDE inspection is tentatively scheduled to be performed beginning in August 2024. While not anticipated, APA reserves the right to delay, suspend, stop and/or cancel all or portions of the work related to the Slab Handling Crane Structural/Mechanical Inspections project at any time with or without cause both prior to and during the NDE structural weld inspection portion of the work with no repercussions from the weld inspection company.
2. It is estimated the NDE structural weld inspection will require approximately 3 weeks per crane to complete working approximately 60 hours per week. The estimated labor and equipment required to adequately execute the NDE inspection per the outlined schedule is as follows:



Alabama Port Authority
Specification Booklet

Project Name APA Pinto Cranes Structural Weld Inspection - **REBID**

Location Mobile, AL

Project # 11371 **Task #** 2 **JUNE 27, 2024**

- a. Two (2) full time weld inspector's at 60 hours per week for 3 weeks per crane.(APA expects continuity of inspectors throughout)
- b. Six (6) full time support labor at 60 hours per week for 3 weeks per crane. (APA provided personnel)
- c. Two (2) 150 – 185 ft. man lifts, full time. (Provided by APA)
- d. Two (2) 60 – 100 ft. man lifts, full time. (Provided by APA)
- e. One (1) 250 - 300 ft. mobile crane with man basket, two (2) weeks per crane. (Provided by APA)

The above estimate assumes minimal downtime for weather and minimal requirements to perform additional repairs discovered during inspection.

3. It is assumed the NDE onsite inspection work will proceed for 6 days per week (Monday – Saturday) at 9-10 hours per day. Cranes will be available 8AM to 6PM and will resume regular operations starting at 7PM.
4. The order of inspection (Crane 1, 2, or 3 first) will depend on APA operations and direction. Once the order is determined, the inspection of the first crane is intended to be executed continuously with the structural NDE inspection of the second crane to begin immediately following the first. Although not guaranteed, the intention is to not bounce back and forth between cranes.

Description of Site

1. The NDE inspection work shall be performed in the area(s) on the dock as designated by the APA.
2. APA will be responsible for clearing the rails and securing all equipment (including all man lifts and mobile cranes) at the end of each work day within the designated work area to allow APA personnel the ability to reposition the crane(s) as needed.
3. The position of the boom during the inspections will be highly consequential to berthing operations. Contractor will coordinate all boom lowering/raising activities with the APA. Upon approval from operations, APA personnel will position the boom as requested to facilitate inspection. The boom shall only be in the down position while active inspection of the boom is being performed. **Please note: Only APA personnel are allowed to operate or perform any crane function or motion during the inspection.**



Alabama Port Authority
Specification Booklet

Project Name APA Pinto Cranes Structural Weld Inspection - **REBID**
Location Mobile, AL
Project # 11371 **Task #** 2 **JUNE 27, 2024**

Project Coordination:

1. The weld inspector is advised that the work will be performed on an active slab handling terminal and that the crane(s) at Pinto Island wharf will be used along the dock for operations at any time during the work. Detailed planning, communication and execution of the work sequence will be required between the inspection team and the APA to minimally impact APA operations.
2. The locations of the cranes (including the crane being inspected) along the wharf during inspection will be contingent on the anticipated vessel berthing operations, which are not possible to predict more than 24 - 48 hours in advance and often change unexpectedly.

Therefore, while not expected to occur frequently, APA operations reserve the ability to temporarily suspend the NDE inspection and relocate the crane to accommodate incoming, outgoing and/or adjacent vessels at any time during the NDE inspection work. Once notified, the support contractor must have all equipment clear and the crane ready to move within 90 min.

3. At the end of each work day the contractor shall notify APA / APTIM that work is complete and request APA personnel secure the crane. At this time, the contractor will advise APA / APTIM of all inspection activities planned for the following day and advise of any assistance (boom raise/lowering, hoist, trolley, etc.) that may be needed.
4. At the beginning of each work day APA personnel will position the crane designated for inspection as far apart from normal APA operational activity as possible. Note: It is not guaranteed the crane will be positioned in the same location along the wharf each day as the crane inspection position will be determined daily by APA operations.

Final Inspection:

1. Upon completion of the work, the contractor shall clean the work site and all grounds occupied by him in connection with the work of all rubbish, surplus and discarded material, equipment, and debris which accumulated during the work. The contractor shall not demobilize until verification in writing is provided from the APA or APA's representative confirming all NDE/repair work is complete.



Alabama Port Authority
Specification Booklet

Project Name APA Pinto Cranes Structural Weld Inspection - **REBID**

Location Mobile, AL

Project # 11371

Task # 2

JUNE 27, 2024

General Notes:

1. Site Conditions - The weld inspector shall be solely responsible for verifying the actual site conditions and how they affect the required work prior to submitting his/her bid. Any discrepancy noted between actual conditions and those described/illustrated within the provided bid documents including OEM drawings, the structural inspection manuals and summary of inspection document shall be promptly brought to the attention of the APA. No additional cost associated with the modifications to the scope of work required due to inaccurate existing conditions will be considered.
2. Protection of Existing Structures - The work required shall be performed in such a manner as not to damage any existing structures or equipment. Any damage thereto by the weld inspectors and/or contractor's operation shall be repaired or replaced by the contractor at no cost to the APA.
3. Workmanship - All work shall be performed in a thorough workmanlike manner and shall follow current industry standards and practice for non-destructive structural inspection and testing.

All NDE weld inspections shall be performed by qualified inspectors and in accordance with AWS D1.1 latest edition for cyclically loaded structures (or APA approved equivalent).

4. Inspection (If needed for repairs) - Quality control shall be the responsibility of the contractor and they shall be capable of performing all necessary inspections. All visual and non-destructive weld inspections shall be performed by qualified inspectors and in accordance with AWS D1.1 (or APA approved equivalent).
5. Compliance with local codes

All work shall be performed shall comply with applicable local code requirements and permits in addition to those specified herein.



Alabama Port Authority
Specification Booklet

Project Name APA Pinto Cranes Structural Weld Inspection - **REBID**

Location Mobile, AL

Project # 11371

Task # 2

JUNE 27, 2024

APPENDIX A

- ①4-0—GANTRY STRUCTURE
- ①5-0—TROLLEY STRUCTURE
- ①6-0—MACHINERY FRAME

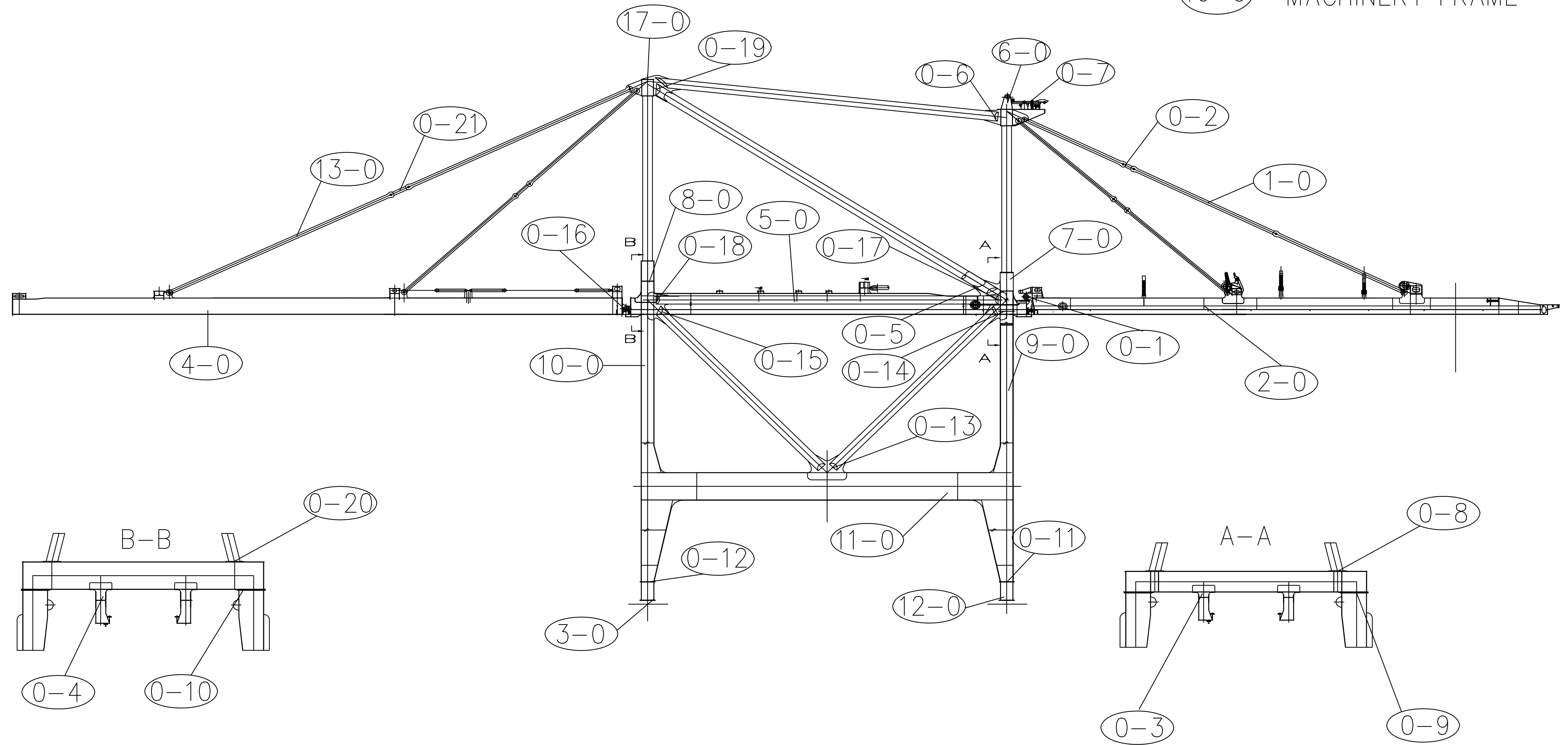

Project:
PINTO CRANES

Content:
SHAFTS OF FORESTAY SYSTEM INSPECTION LOCATIONS

Draw No:
0-2

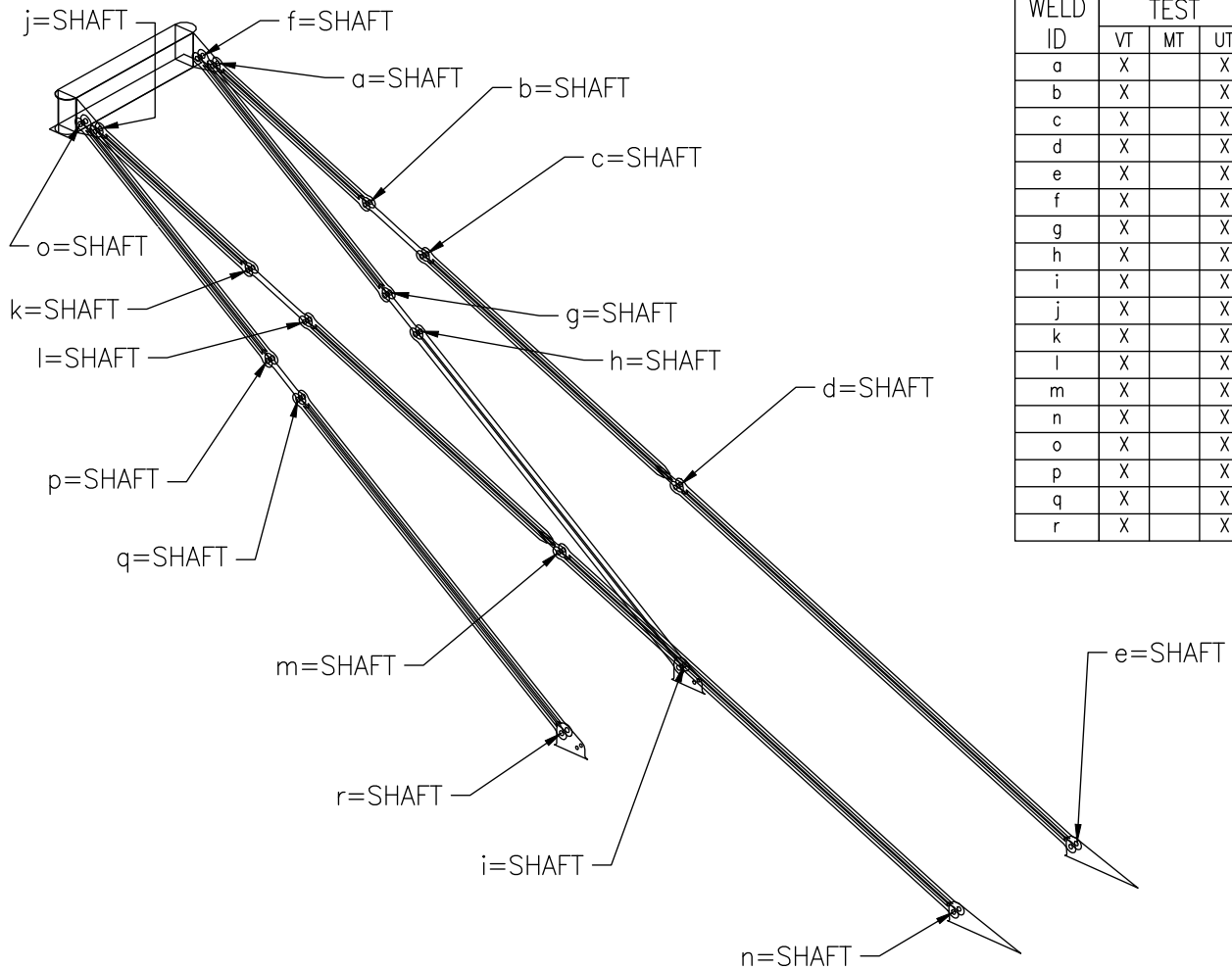

WELD ID	TEST		
	VT	MT	UT
a	X		X
b	X		X
c	X		X
d	X		X
e	X		X
f	X		X
g	X		X
h	X		X
i	X		X
j	X		X
k	X		X
l	X		X
m	X		X
n	X		X
o	X		X
p	X		X
q	X		X
r	X		X

NOTE:
J-R SHAFTS ARE A-I EQUIVALENTS ON THE OTHER SIDE OF THE CRANE.

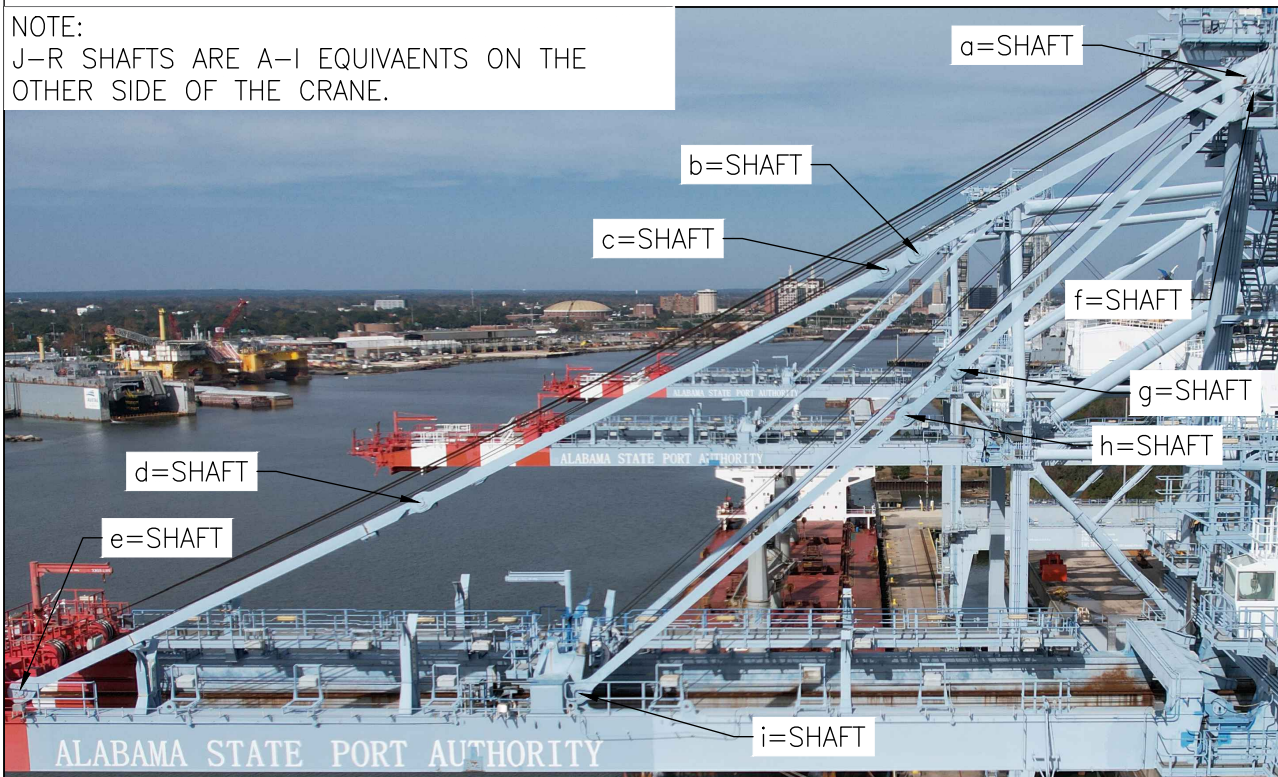

STRUCTURAL MAINTENANCE MANUAL

Crane Mfg: _____

CRANE NO. ____

Component Designation: _____
 Inspection Manual Pg. No: ____

Component Description: _____

INSPECTION RECORD						Main Hoist Hour Reading: _____	hrs	
Weld ID	Test			Accept	Reject	Notes	Insp. By	Date
	VT	MT	UT					
A								
B								
C								
D								
E								
F								
G								
H								
I								
J								
K								
L								
M								
N								
O								
P								
Q								
R								
S								
T								
U								
V								
W								
X								
Y								
Z								
AA								
BB								
CC								
DD								
EE								
FF								
GG								
HH								
II								
JJ								
KK								
LL								
MM								
NN								
OO								
PP								

Comments:

ASPA PINTO ISLAND

Project:
PINTO CRANES

Content:
LOWER DIAGONAL TO WS LEG CONNECTION INSPECTION LOCATIONS

Draw No:
0-14

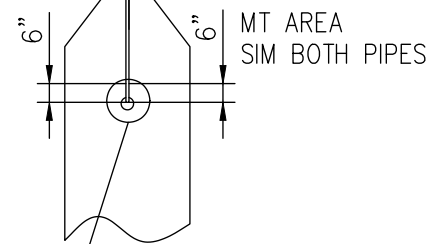
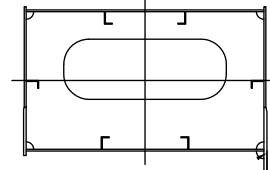
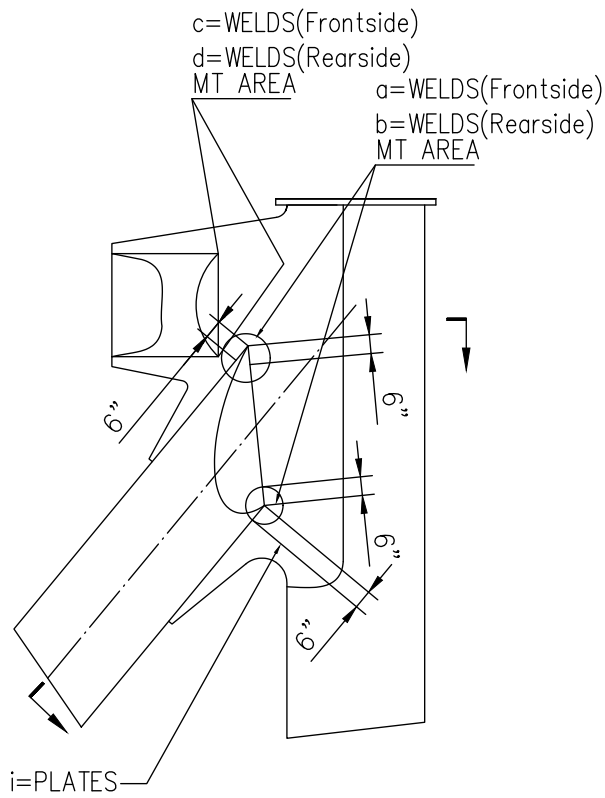

WELD ID	TEST		
	VT	MT	UT
a	X	X	
b	X	X	
c	X	X	
d	X	X	
e	X	X	
f	X	X	
g	X	X	
h	X	X	
i	X		



STRUCTURAL MAINTENANCE MANUAL

Crane Mfg: _____

CRANE NO. ____

Component Designation: _____
 Inspection Manual Pg. No: ____

Component Description: _____

INSPECTION RECORD					Main Hoist Hour Reading: _____ hrs			
Weld ID	Test			Accept	Reject	Notes	Insp. By	Date
	VT	MT	UT					
A								
B								
C								
D								
E								
F								
G								
H								
I								
J								
K								
L								
M								
N								
O								
P								
Q								
R								
S								
T								
U								
V								
W								
X								
Y								
Z								
AA								
BB								
CC								
DD								
EE								
FF								
GG								
HH								
II								
JJ								
KK								
LL								
MM								
NN								
OO								
PP								

Comments:

ASPA PINTO ISLAND

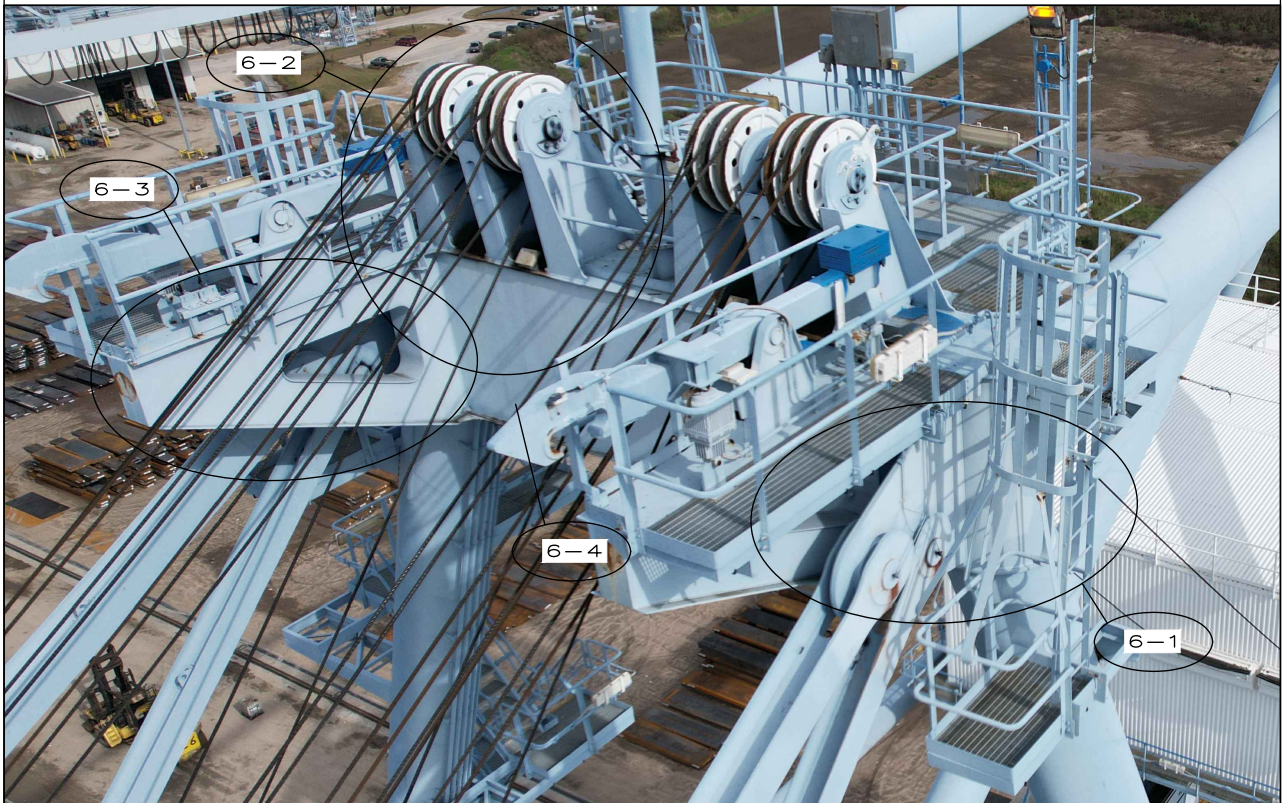
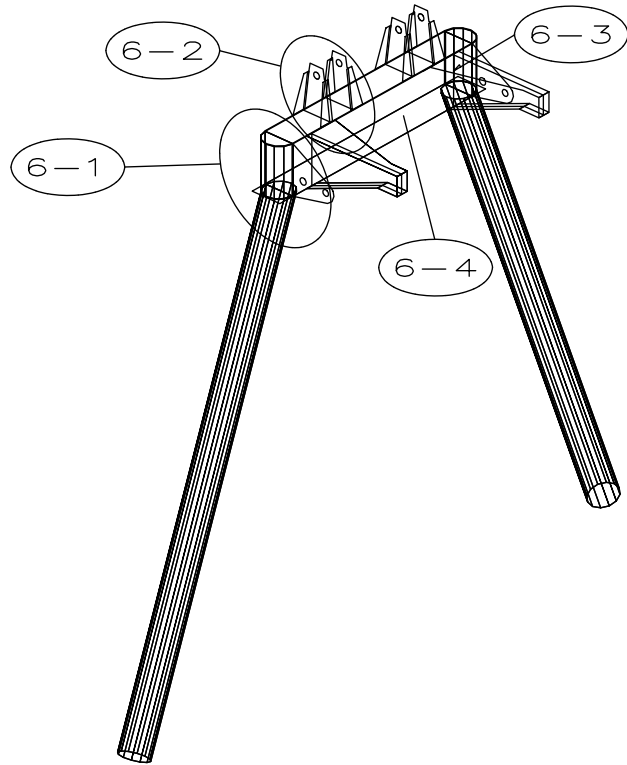

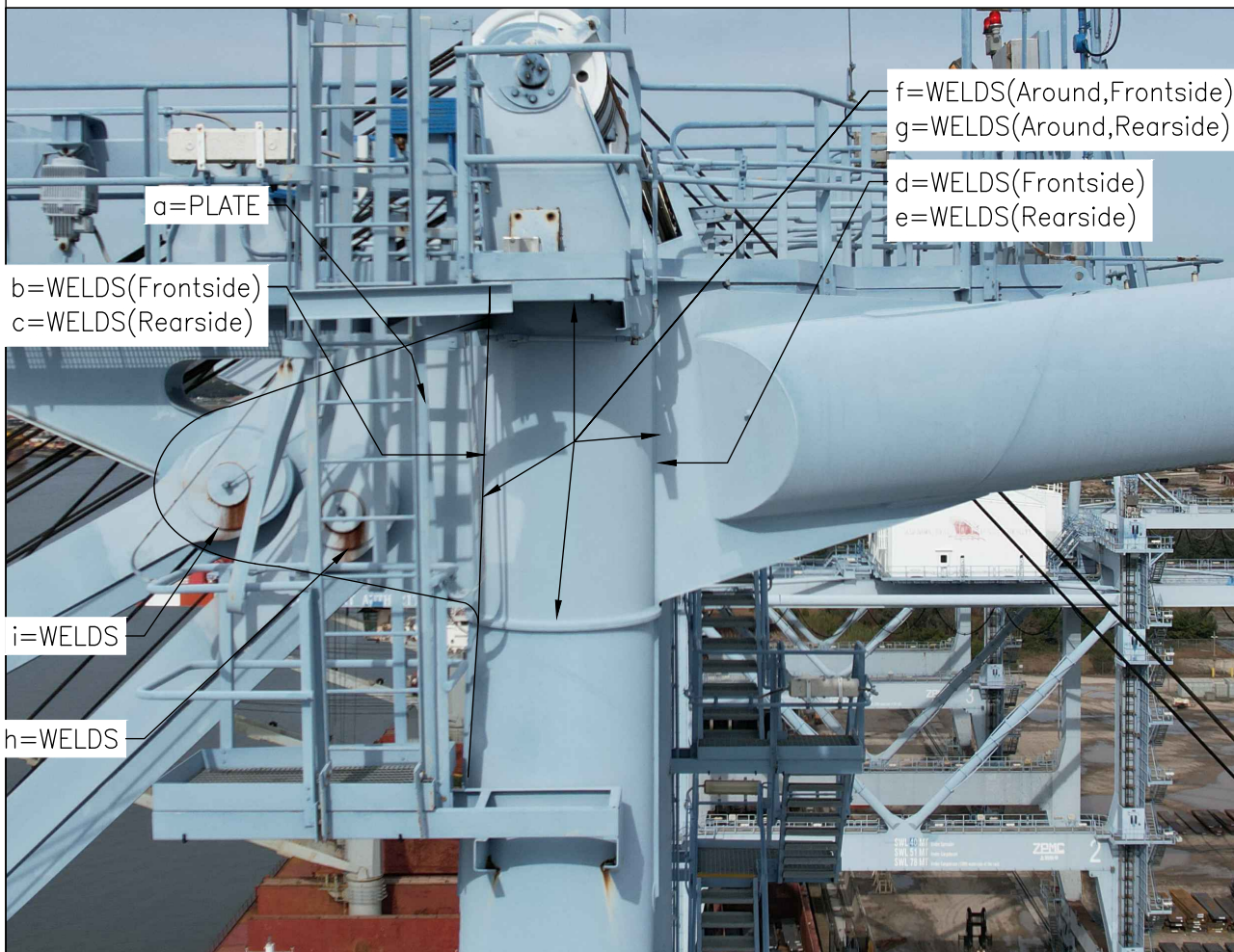
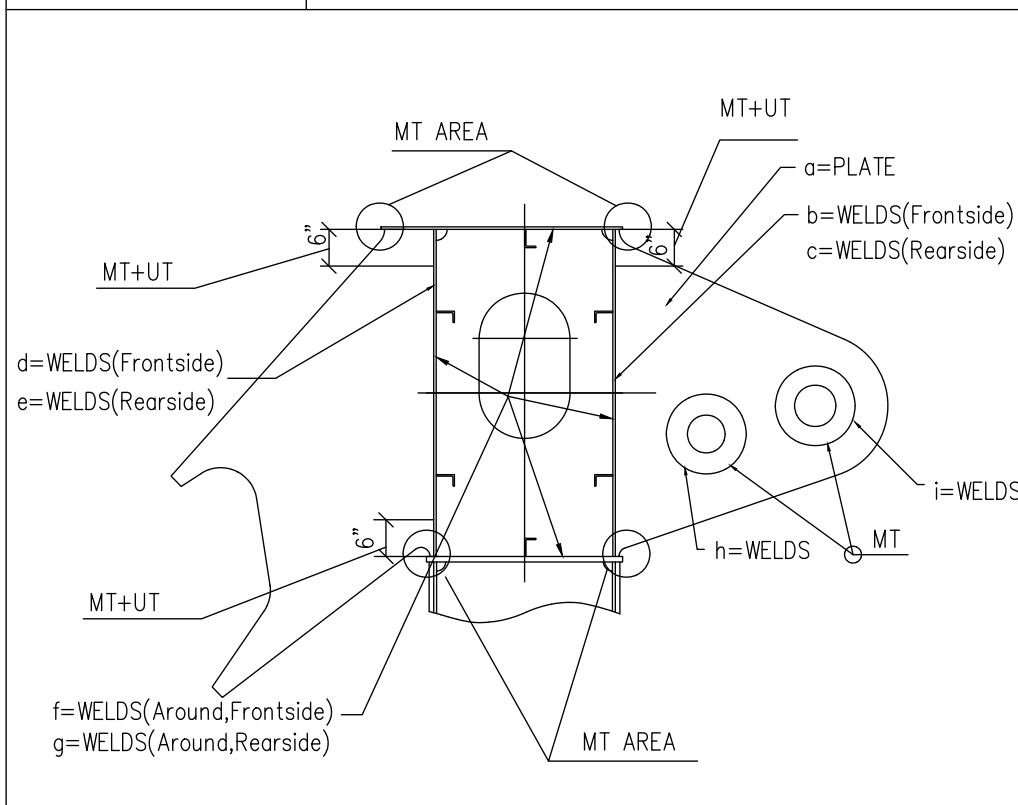

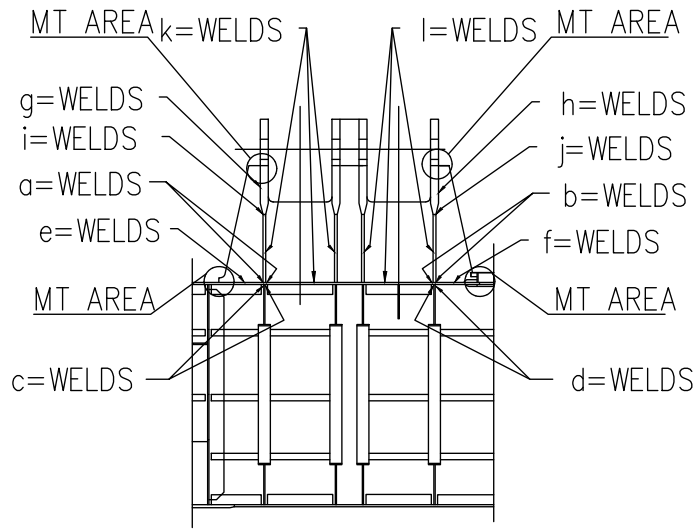

WELD ID	TEST		
	VT	MT	UT
a	X		
b	X		
c	X		
d	X		
e	X	X	
f	X	X	
g	X	X	
h	X	X	
i	X	X	X
j	X	X	X
k	X		
l	X		

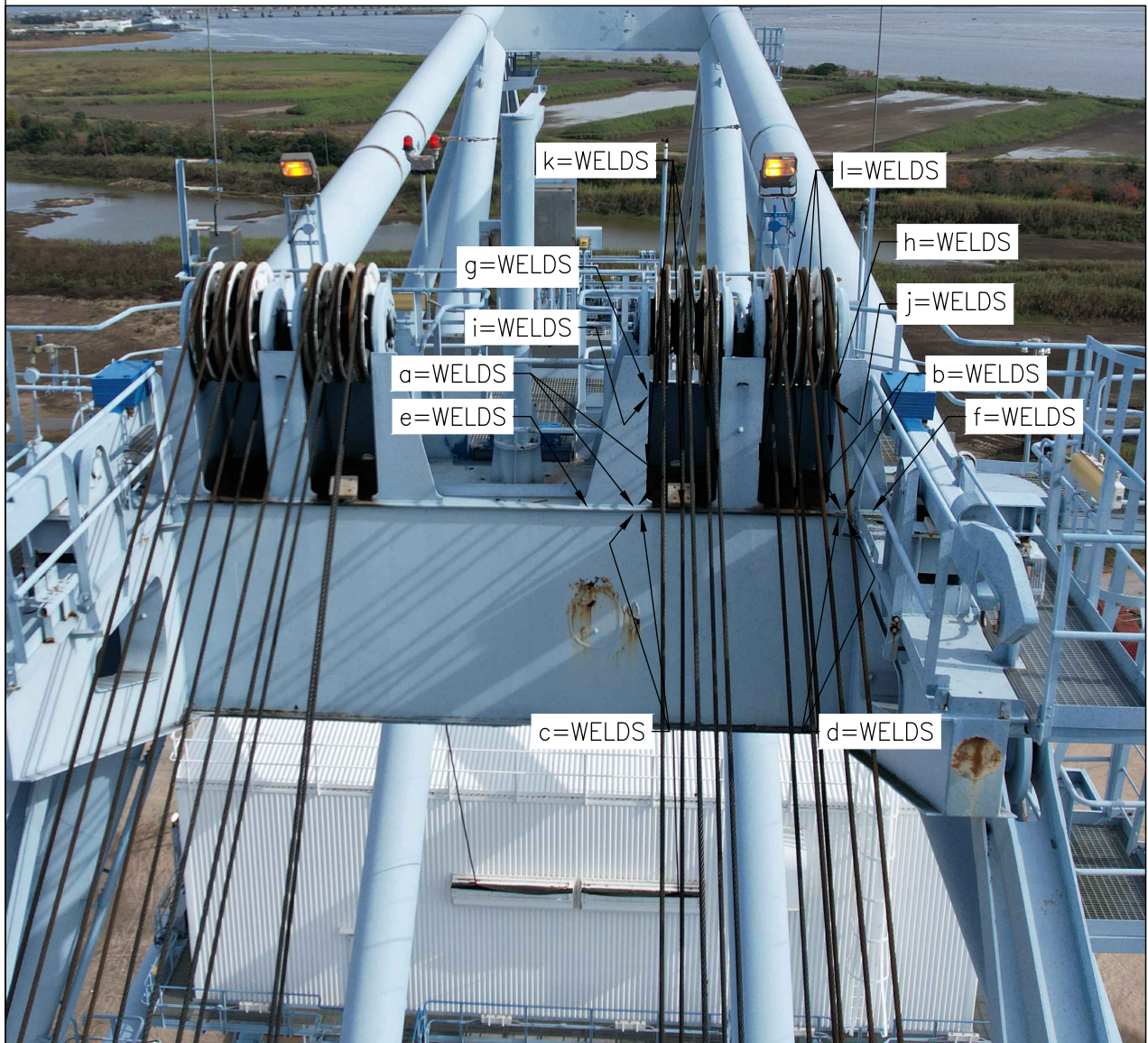

WELD ID	TEST		
	VT	MT	UT
a	X		
b	X		
c	X		
d	X		
e	X		
f	X		

e=WELDS(Frontside)
f=WELDS(Rearside)

a=WELDS

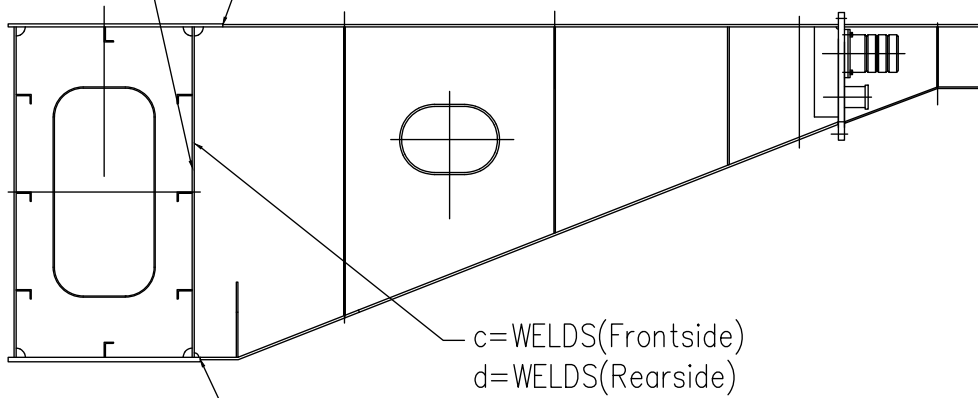

c=WELDS(Frontside)
d=WELDS(Rearside)

b=WELDS

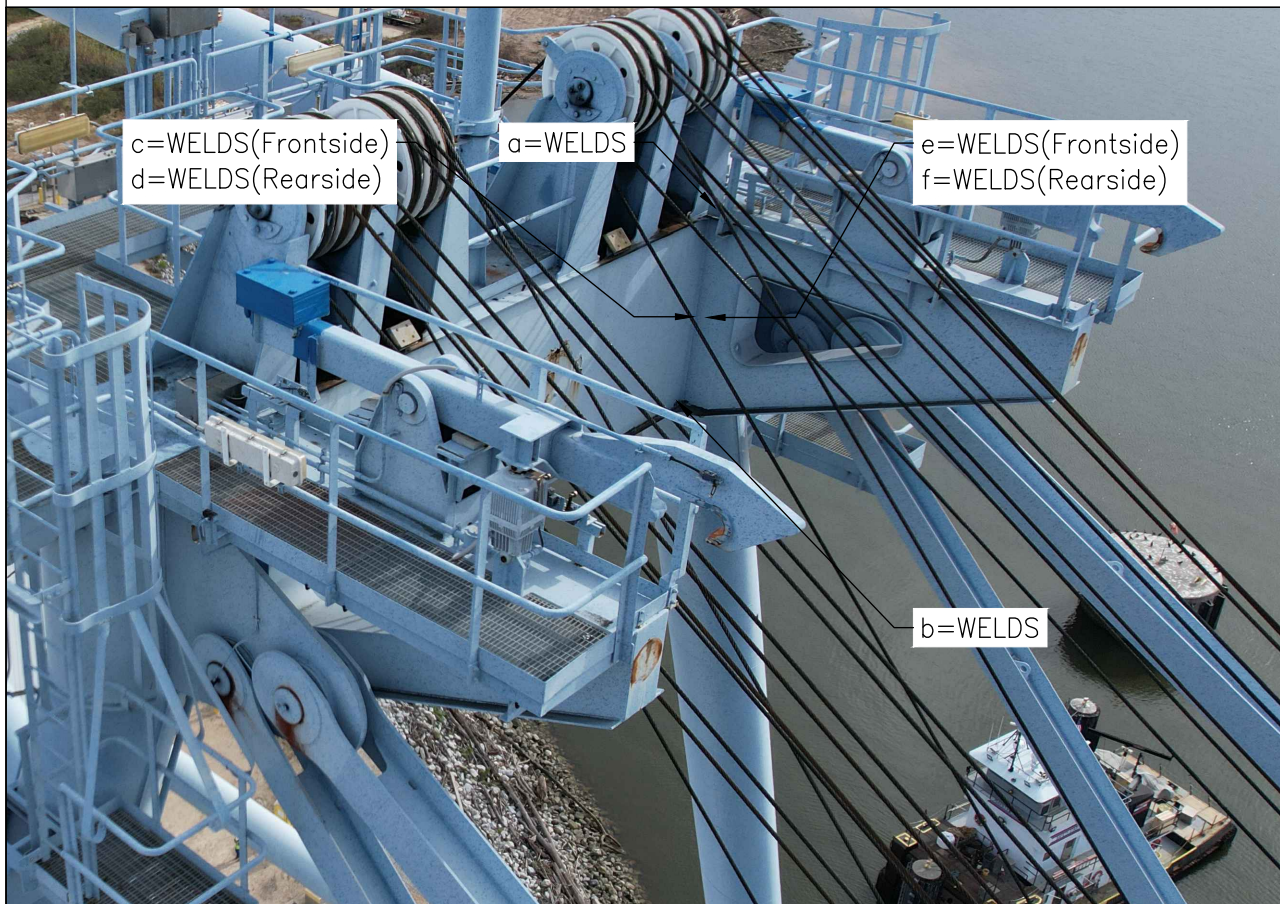

c=WELDS(Frontside)
d=WELDS(Rearside)

a=WELDS

e=WELDS(Frontside)
f=WELDS(Rearside)

b=WELDS

WELD ID	TEST		
	VT	MT	UT
a	X		
b	X		
c	X		
d	X		
e	X		
f	X		
g	X		
h	X		

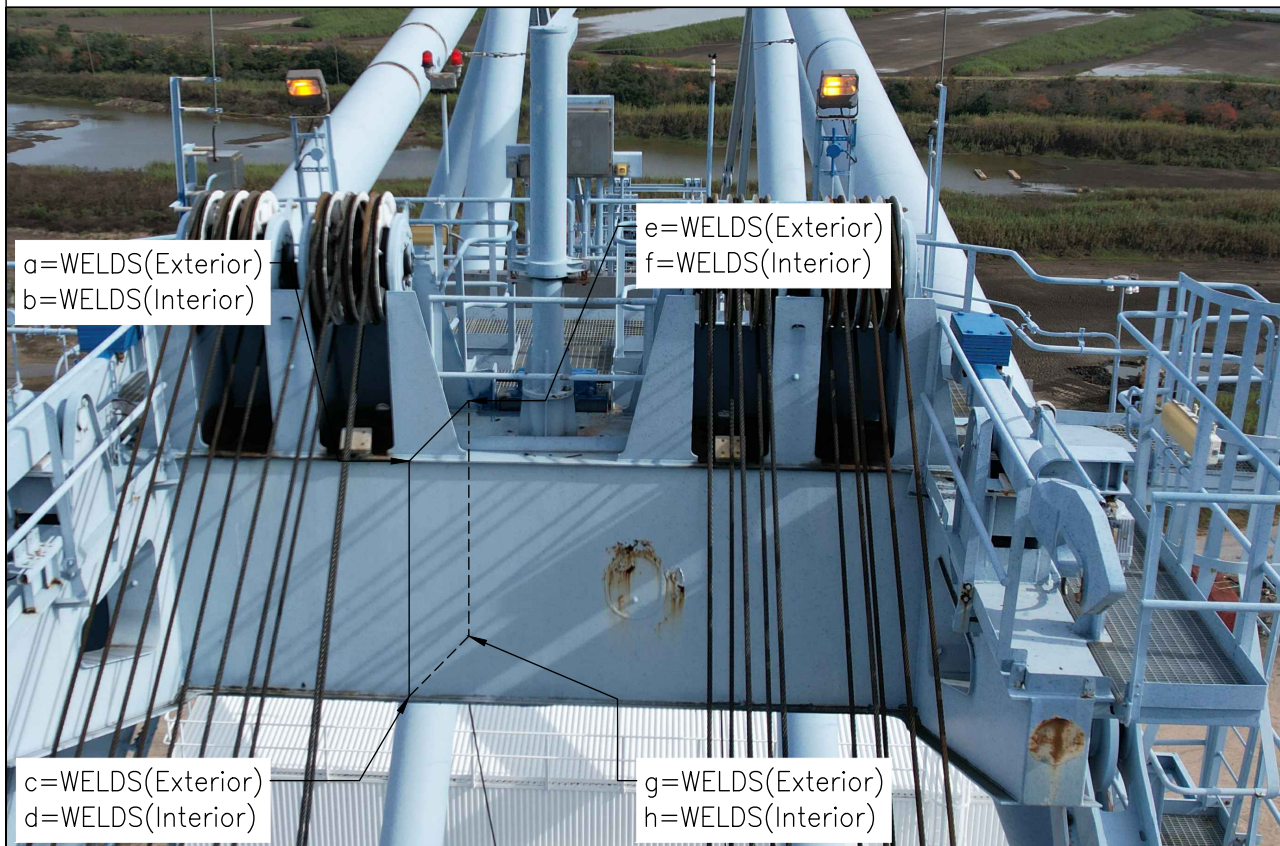
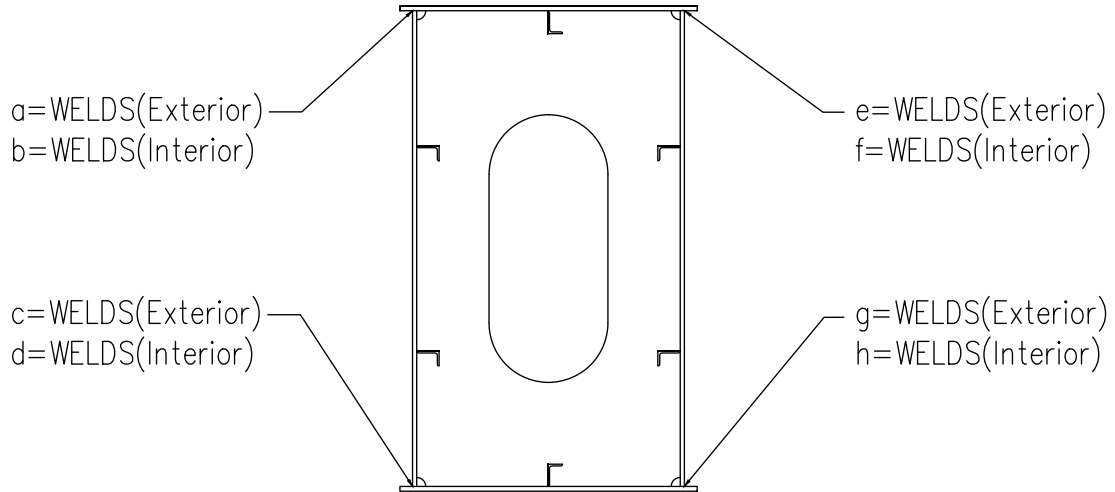

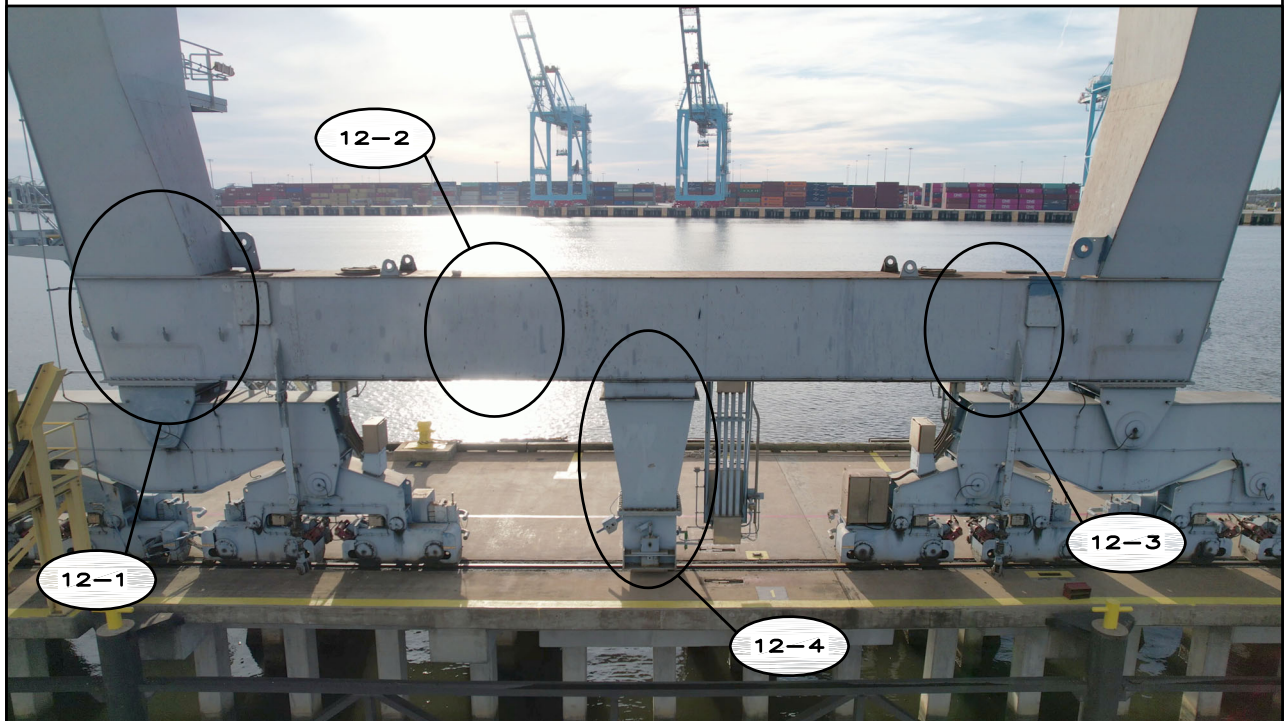
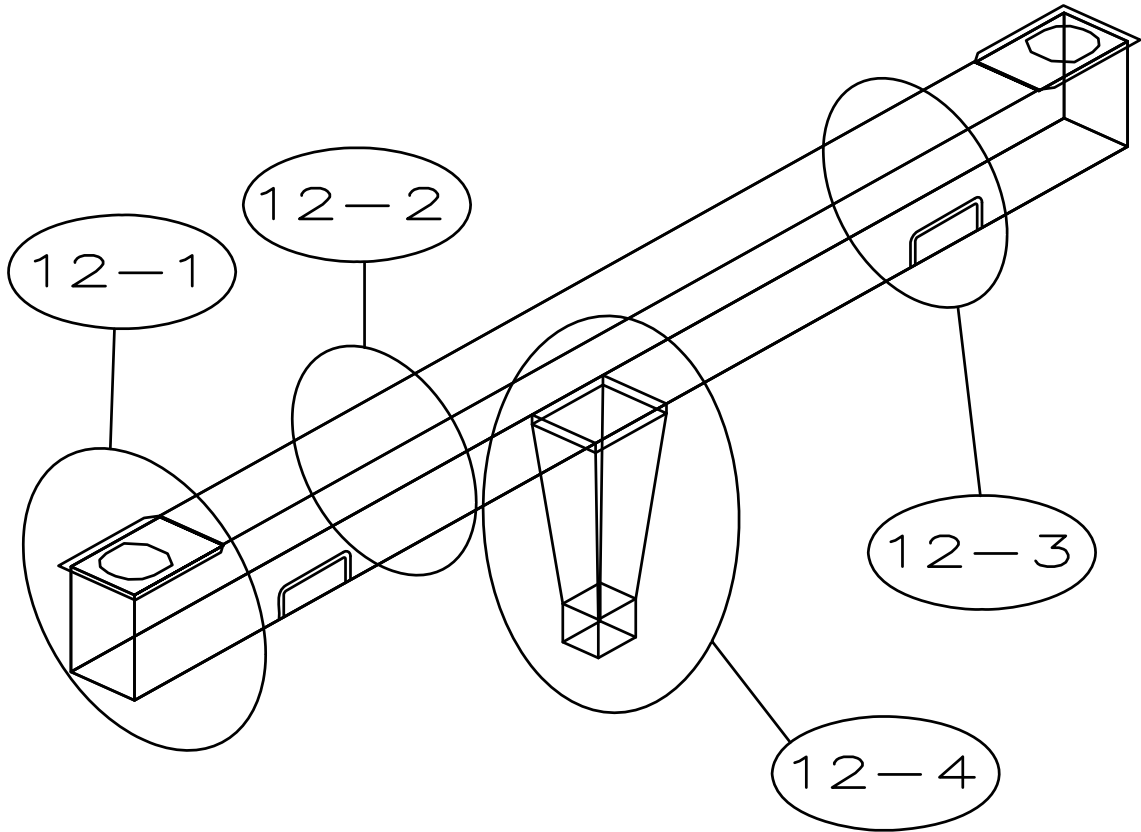

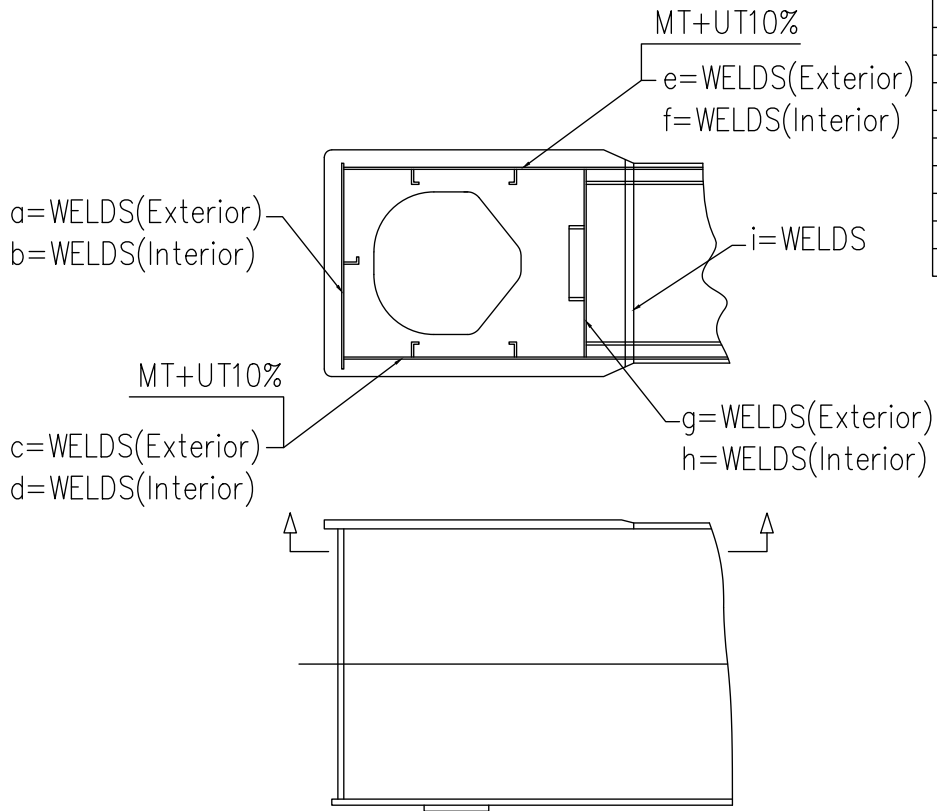

Project:
 PINTO CRANES

 Content:
 WATERSIDE SILL BEAM INSPECTION LOCATIONS

 Draw No:
 12-2

WELD ID	TEST		
	VT	MT	UT
a	X		
b	X		
c	X		
d	X		
e	X		
f	X		
g	X		
h	X		

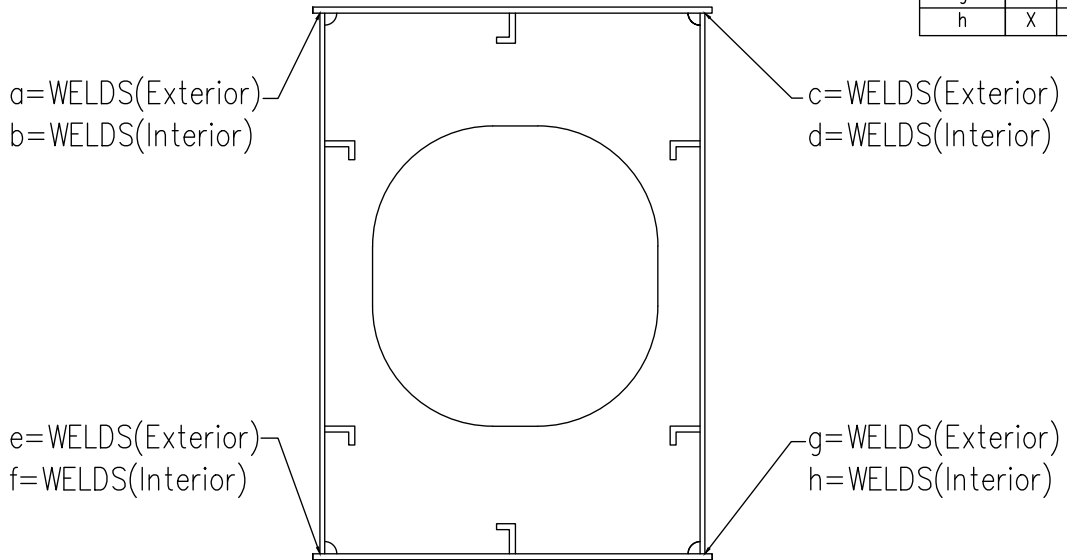

Project:
 PINTO CRANES

 Content:
 WATERSIDE SILL BEAM INSPECTION LOCATIONS

 Draw No:
 12-3

WELD ID	TEST		
	VT	MT	UT
a	X	X	X
b	X	X	X
c	X	X	X
d	X		X

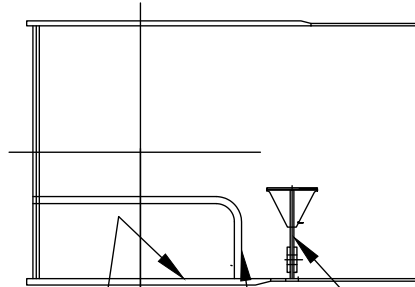

c=WELDS(Round)

d WELDS

a=WELDS(Waterside) MT+UT

b=WELDS(Landside)



Project:
 ASPA 36t SSC

 Content:
 WATERSIDE SILL BEAM INSPECTION LOCATIONS

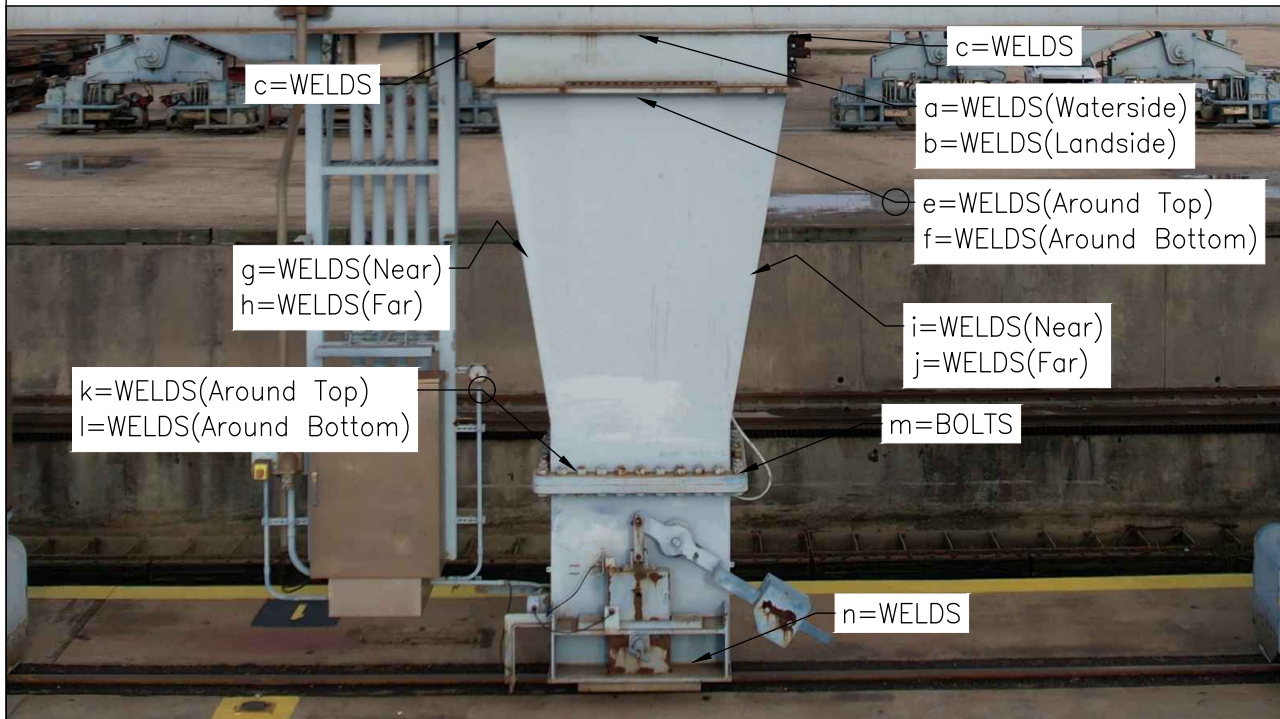
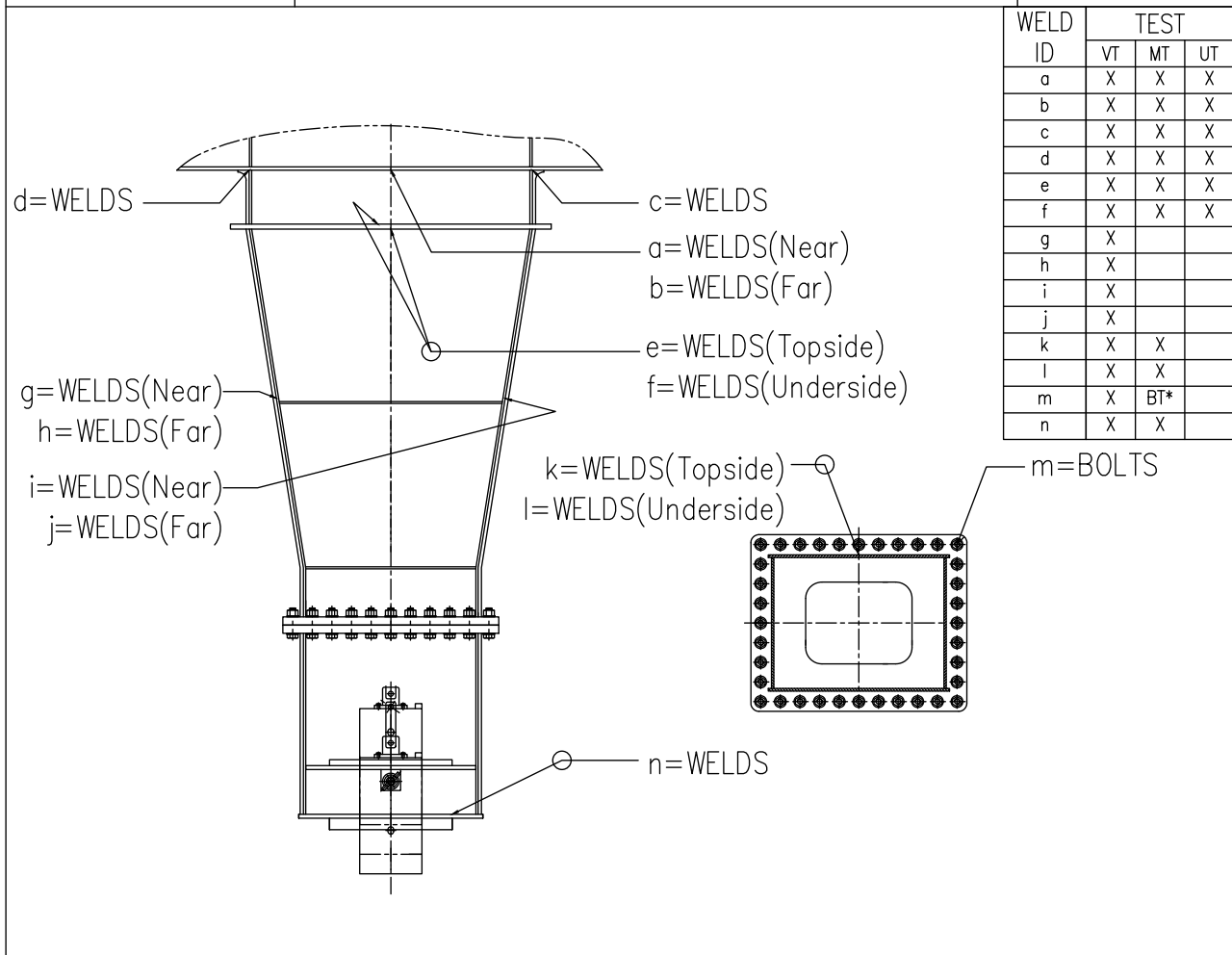
 Draw No:
 12-4



Alabama Port Authority
Specification Booklet

Project Name APA Pinto Cranes Structural Weld Inspection - **REBID**

Location Mobile, AL

Project # 11371 **Task #** 2

JUNE 27, 2024

APPENDIX B

STRUCTURAL MAINTENANCE MANUAL

Crane Mfg: _____

CRANE NO. ____

Component Designation: _____
 Inspection Manual Pg. No: ____

Component Description: _____

INSPECTION RECORD					Main Hoist Hour Reading: _____ hrs			
Weld ID	Test			Accept	Reject	Notes	Insp. By	Date
	VT	MT	UT					
A								
B								
C								
D								
E								
F								
G								
H								
I								
J								
K								
L								
M								
N								
O								
P								
Q								
R								
S								
T								
U								
V								
W								
X								
Y								
Z								
AA								
BB								
CC								
DD								
EE								
FF								
GG								
HH								
II								
JJ								
KK								
LL								
MM								
NN								
OO								
PP								

Comments:

ASPA PINTO ISLAND



Alabama Port Authority
Specification Booklet

Project Name APA Pinto Cranes Structural Weld Inspection - **REBID**

Location Mobile, AL

Project # 11371 **Task #** 2 **JUNE 27, 2024**

APPENDIX C

Summary of Inspection Document - Crane 1

Designation	Sheet Title	# of Welds	# of Sheets	VT Only Area	MT/UT/BT	Bolt Insp.	Weld Insp.	Weld L >2'	Weld L <2'	Inspector	Completed?
0-1	BOOM HINGE	8	2	0	8	4	4	0	4		
0-2	SHAFTS OF FORESTAY	18	1	0	18	0	18	0	18		
0-3	TG TO WS TGSB	14	2	0	14	0	14	10	4		
0-4	TG TO LS TGSB	14	2	0	14	0	14	10	4		
0-5	UPPER DIAGONAL TO WS TGSB	7	2	1	6	0	6	6	0		
0-6	UPPER HORIZONTAL TO WS APEX	5	2	1	4	0	4	4	0		
0-7	APEX BEAM TO BOOM LATCH	2	2	1	1	0	1	0	1		
0-8	APEX LEG TO WS TGSB	1	2	0	1	0	1	1	0		
0-9	WS LEG TO TGSB	3	2	2	1	1	0	0	0		
0-10	LS LEG TO TGSB	3	2	2	1	1	0	0	0		
0-11	WS LEG TO SILL BEAM	1	2	0	1	0	1	1	0		
0-12	LS LEG TO SILL BEAM	1	2	0	1	0	1	1	0		
0-13	LOWER DIAGONAL TO PORTAL BEAM	3	2	1	2	0	2	0	2		
0-14	LOWER DIAGONAL TO WS LEG	9	2	1	8	0	8	0	8		
0-15	LOWER DIAGONAL TO LS LEG	9	2	1	8	0	8	0	8		
0-16	GIRDER HINGE	5	2	0	5	0	5	0	5		
0-17	HORIZONTAL DIAGONAL TO LS TGSB	3	2	1	2	0	2	2	0		
0-18	HORIZONTAL DIAGONAL TO WS TGSB	3	2	1	2	0	2	2	0		
0-19	UPPER DIAGONAL TO LS APEX BEAM	10	2	2	8	0	8	4	4		
0-20	APEX LEG TO LS TGSB	1	2	0	1	0	1	1	0		
0-21	SHAFTS OF BACKSTAY SYSTEM	16	1	0	16	0	16	0	16		
1-0	FORESTAY BAR SYSTEM										
1-1	DRAWBAR 1-1 INSPECTION LOCATIONS	5	2	2	3	0	3	0	3		
1-2	TIE PLATE 1-2 INSPECTION LOCATIONS	2	2	1	1	0	1	1	0		
1-3	DRAWBAR 1-3 INSPECTION LOCATIONS	5	2	2	3	0	3	0	3		
1-4	DRAWBAR 1-4 INSPECTION LOCATIONS	9	2	3	6	0	6	0	6		
1-5	DRAWBAR 1-5 INSPECTION LOCATIONS	5	2	2	3	0	3	0	3		
1-6	TIE PLATE 1-6 INSPECTION LOCATIONS	2	2	1	1	0	1	1	0		
1-7	DRAWBAR 1-7 INSPECTION LOCATIONS	5	2	2	3	0	3	0	3		
2-0	BOOM										
2-1	FIRST BOOM CROSSTIE	15	2	6	9	0	9	4	5		
2-2	FORESTAY GUIDES TYP.	5	6	5	0	0	0	0	0		
2-3	TYPICAL BOOM CROSS SECTION	9	2	0	9	0	9	9	0		
2-4	BOOM LATCH GUIDE	7	2	6	1	0	1	1	0		
2-5	SECOND BOOM CROSSTIE	11	2	7	4	0	4	4	0		
2-6	SECOND BOOM CROSSTIE REEVING	6	2	0	6	0	6	2	4		
2-7	END BEAM OF BOOM	10	2	10	0	0	0	0	0		
2-8	THIRD BOOM CROSSTIE	11	2	7	4	0	4	4	0		
2-9	THIRD BOOM CROSSTIE REEVING	8	2	0	8	0	8	4	4		
3-0	LANDSIDE SILL BEAM										
3-1	LANDSIDE SILL BEAM AT LANDSIDE LEG	9	2	4	5	0	5	5	0		
3-2	TYPICAL LANDSIDE SILL BEAM SECTION	8	1	8	0	0	0	0	0		
3-3	LANDSIDE SILL BEAM AT GANTRY	4	2	0	4	0	4	3	1		

Designation	Sheet Title	# of Welds	# of Sheets	VT Only Area	MT/UT/BT	Bolt Insp.	Weld Insp.	Weld L >2'	Weld L <2'	Inspector	Completed?
3-4	LANDSIDE STOW PIN	14	1	4	10	1	9	8	1		
4-0	END GIRDER										
4-1	END GIRDER CROSSTIE BEAM 1	11	2	9	2	0	2	0	2		
4-2	END GIRDER DIAGONAL BRACE CONNECTORS	10	2	4	6	0	6	0	6		
4-3	END GIRDER CROSSTIE BEAM 2	13	2	9	4	0	4	2	2		
4-4	END GIRDER CROSSTIE BEAM 3	12	2	8	4	0	4	2	2		
4-5	TYPICAL END GIRDER CROSS SECTION	9	2	0	9	0	9	6	3		
4-6	END GIRDER END BEAM ATTACHMENTS	3	2	0	3	0	3	0	3		
4-7	END GIRDER END BEAM	13	2	13	0	0	0	0	0		
5-0	MIDDLE GIRDER										
5-1	MIDDLE GIRDER AT BOOM HINGE	7	2	2	5	0	5	2	3		
5-2	MIDDLE GIRDER WS DIAGONAL CONNECTORS	12	2	8	4	0	4	0	4		
5-3	TYPICAL MIDDLE GIRDER SECTION	9	2	1	8	0	8	5	3		
5-4	MIDDLE GIRDER LS DIAGONAL CONNECTORS	3	2	0	3	0	3	1	2		
5-5	MIDDLE GIRDER AT END GIRDER HINGE	4	2	0	4	0	4	2	2		
6-0	WS APEX BEAM										
6-1	WS APEX FORESTAY AND DIAGONAL PLATES	8	2	2	6	0	6	4	2		
6-2	WS APEX BEAM ROPE REEVING	12	2	4	8	0	8	0	8		
6-3	WS APEX BEAM BOOM LATCH	8	2	8	0	0	0	0	0		
6-4	TYPICAL WS APEX CROSS SECTION	4	1	4	0	0	0	0	0		
7-0	WS TROLLEY GIRDER SUPPORT BEAM										
7-1	WS TGSB AT APEX LEG AND WS LEG	8	2	0	8	0	8	8	0		
7-2	WS TGSB AT WS TGSB	8	2	3	5	0	5	3	2		
7-3	TYPICAL WS TGSB CROSS SECTION	8	1	0	8	0	8	4	4		
8-0	LS TROLLEY GIRDER SUPPORT BEAM										
8-1	LS TGSB AT APEX LEG AND WS LEG	8	2	0	8	0	8	8	0		
8-2	LS TGSB AT WS TGSB	6	2	2	4	0	4	4	0		
8-3	TYPICAL LS TGSB CROSS SECTION	8	1	0	8	0	8	4	4		
9-0	WATERSIDE LEGS										
9-1	WATERSIDE LEG AT WS TGSB	9	2	4	5	0	5	5	0		
9-2	TYPICAL WATERSIDE LEG CROSS SECTION	8	2	0	8	0	8	4	4		
9-3	WATERSIDE LEG DIAGONAL CONNECTOR	6	2	0	6	0	6	3	3		
10-0	LANDSIDE LEGS										
10-1	LANDSIDE LEG AT LS TGSB	9	2	4	5	0	5	5	0		
10-2	TYPICAL LANDSIDE LEG CROSS SECTION	8	2	0	8	0	8	4	4		
10-3	LANDSIDE LEG DIAGONAL CONNECTOR	6	2	0	6	0	6	3	3		
11-0	PORTAL BEAM										
11-1	TYPICAL PORTAL BEAM CROSS SECTION	8	2	8	0	0	0	0	0		
11-2	PORTAL BEAM DIAGONAL CONNECTOR	3	2	0	3	0	3	3	0		
12-0	WATERSIDE SILL BEAM										
12-1	WATERSIDE SILL BEAM AT WS LEG	9	2	5	4	0	4	4	0		
12-2	TYPICAL WATERSIDE SILL BEAM CROSS SECTION	8	1	8	0	0	0	0	0		
12-3	WATERSIDE SILL BEAM AT GANTRY	4	2	0	4	0	4	3	1		
12-4	WATERSIDE STOW PIN	14	1	4	10	1	9	8	1		
13-0	BACKSTAY BAR SYSTEM										
13-1	DRAWBAR 13-1 INSPECTION LOCATIONS	5	2	2	3	0	3	0	3		

Designation	Sheet Title	# of Welds	# of Sheets	VT Only Area	MT/UT/BT	Bolt Insp.	Weld Insp.	Weld L >2'	Weld L <2'	Inspector	Completed?
13-2	TIE PLATE 13-2 INSPECTION LOCATIONS	2	2	1	1	0	1	1	0		
13-3	DRAWBAR 13-3 INSPECTION LOCATIONS	5	2	2	3	0	3	0	3		
13-4	DRAWBAR 13-4 INSPECTION LOCATIONS	5	2	2	3	0	3	0	3		
13-5	TIE PLATE 13-5 INSPECTION LOCATIONS	2	2	1	1	0	1	1	0		
13-6	DRAWBAR 13-6 INSPECTION LOCATIONS	5	2	2	3	0	3	0	3		
14-0	GANTRY STRUCTURE										
14-1	MAIN EQUALIZER	7	4	0	7	0	7	7	0		
14-2	MAIN EQUALIZER PIN	12	1	4	8	4	4	0	4		
14-3	SECONDARY EQUALIZER	7	8	0	7	0	7	6	1		
14-4	SECONDARY EQUALIZER PIN	16	1	8	8	0	8	0	8		
14-5	BOGIE	32	1	32	0	0	0	0	0		
14-6	BOGIE PIN	32	1	16	16	0	16	0	16		
14-7	WHEEL SHAFTS	32	1	32	0	0	0	0	0		
15-0	TROLLEY STRUCTURE										
15-1	TROLLEY STRUCTURE LS END STRUCTURE	6	2	6	0	0	0	0	0		
15-2	TROLLEY STRUCTURE WHL SUPPORT SECTION	2	4	0	2	0	2	0	2		
15-3	TROLLEY STRUCTURE WS AND LS STOPS	4	2	4	0	0	0	0	0		
15-4	TROLLEY STRUCTURE SPREADER BEAMS	4	2	0	4	0	4	4	0		
15-5	TROLLEY STRUCTURE BEAM CONNECTIONS	7	2	5	2	0	2	2	0		
15-6	TROLLEY STRUCTURE CAB SUPPORT	16	2	10	6	1	5	2	3		
15-7	TROLLEY STRUCTURE DIAGONALS	4	2	1	3	0	3	0	3		
16-0	MACHINERY FRAME										
16-1	MACHINERY FRAME BOLTED CONNECTIONS	16	1	8	8	8	0	0	0		
16-2	MACHINERY FRAME PERIMETER BEAMS	5	4	5	0	0	0	0	0		
16-3	MACHINERY FRAME INTERIOR BEAMS	5	2	5	0	0	0	0	0		
16-4	MACHINERY FRAME WIRE ROPE SUPPORT	8	4	8	0	0	0	0	0		
17-0	LS APEX BEAM										
17-1	LS APEX BACKSTAY AND DIAGONAL PLATES	12	2	2	10	0	10	6	4		
17-2	TYPICAL LS APEX BEAM CROSS SECTION	4	1	4	0	0	0	0	0		

			VT ONLY	MT/UT/BT	BT	WELD INSP	APPROX > 2'	APPROX < 2'	
TOTAL INSPECTION LINE ITEMS	1498		622	876		28	848	454	394
			42%	58%					